



www.monoequip.com



“MERLIN”

“L” SEALER

SPARES MANUAL

MACHINE NO.FG480

When ordering spares please quote the **machine serial number** which can be found on the silver information plate of the machine and on the front cover of your manual.

MONO EQUIPMENT
Queensway
Swansea West Industrial Estate
Swansea. SA5 4EB UK

Tel. +44(0)1792 561234
email: spares@monoequip.com
Spares Tel. +44(0)1792 564039
Fax. 01792 561016

MERLIN SPARES

PAGE

RECOMMENDED SPARES

 - 3

MAIN COMPONENT PARTS LAYOUT

 - 4

SEALING ARM PARTS LAYOUT

 - 5

ELECTRICAL PARTS LAYOUT

 - 6

MANDREL PARTS

 - 3

FAULT TRACING TABLE

 - 3

RECOMMENDED SPARES

The machine is supplied with a basic spares kit, however, we recommend that in order to minimise machine down time, users should at least hold the following:-

1 - Reel 22swg Seal Wire ----- Pt No B944-95-002 (order by Metre lengths)



1 - Roll 13mm wide P.T.F.E. Glass Tape (1.2Mtrs) – Pt No A900-12-120



1 - Wireholder with spring. ----- Pt No S480-04-00000

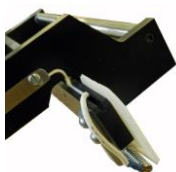

Consisting of :

- 480-04-00008 wireholder block
- 480-04-00019 wireholder pin
- A900-19-090 Spring
- B842-62-030 Nylon screw insulator

1 - Packet 1amp. Fuses. (10) – For panel Pt No B842-85-025



1 - Packet 13 amp. Fuses (10) – For supply plug Pt No B842-85-011



For these and other spares please contact Mono spares dept. Tel. 01792 564039

MAIN COMPONENTS PARTS

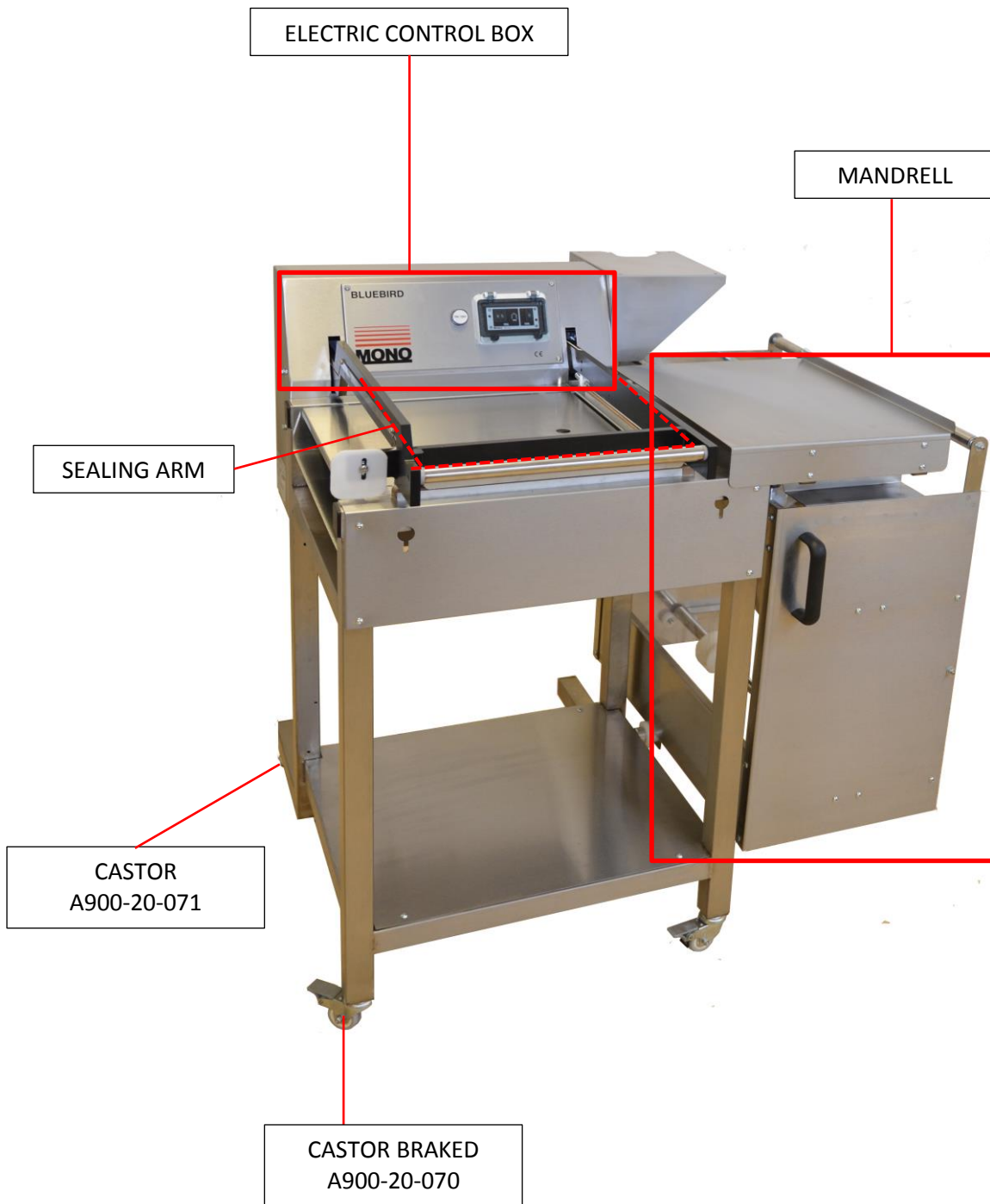

SEALING ARM PARTS LAYOUT

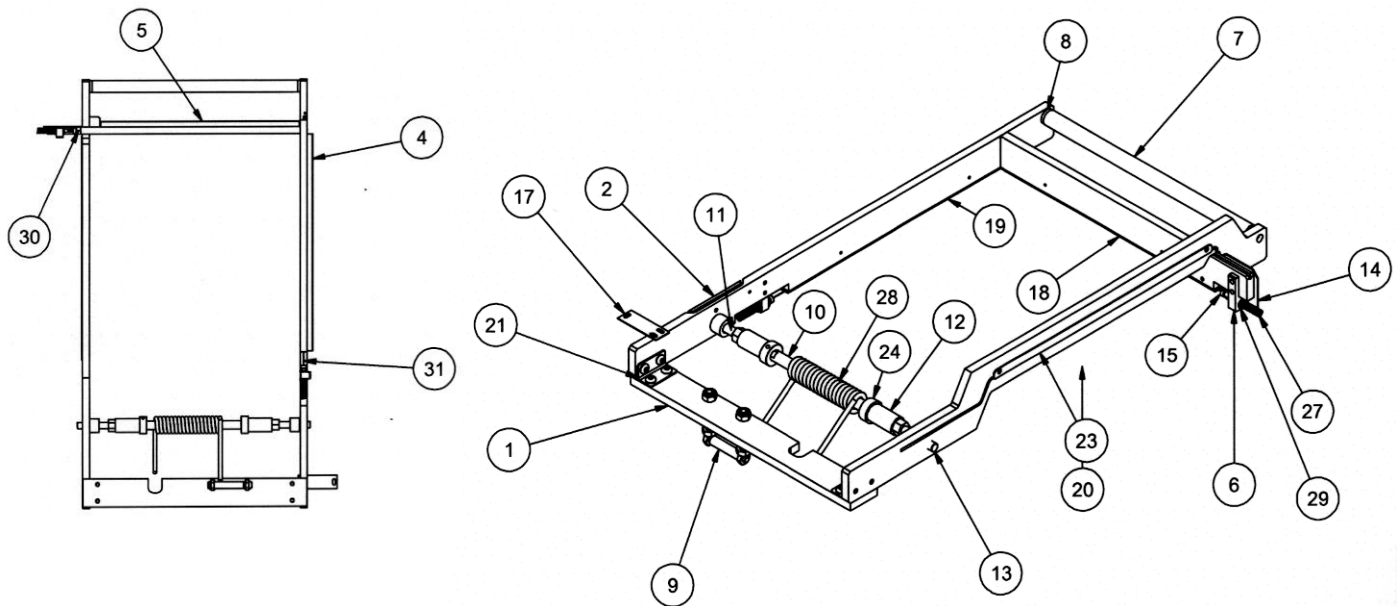

<u>ITEM</u>	<u>PART NUMBER</u>	<u>DESCRIPTION</u>	<u>QTY</u>
1	480-04-00001	BALANCE WEIGHT	1
2	480-04-00002	SEALING ARM	1
3	480-04-00003	SEALING ARM FRONT	1
4	480-04-00006	SIDE CHEEK	1
5	480-04-00007	FRONT CHEEK	1
6	480-04-00008	WIREHOLDER BLOCK	2
7	480-04-00009	HANDLE	1
8	480-04-00011	HANDLE END PLUG	2
9	480-04-00012	EYEBOLT PIN	1
10	480-04-00013	SPRING SPINDLE	1
11	480-04-00015	PIVOT SPACER	2
12	480-04-00016	SPINDLE SLEEVE	2
13	480-04-00017	BEARING PIN	2
14	480-04-00018	WIRE GUARD	1
15	480-04-00019	WIREHOLDER PIN	2
16	480-04-00021	EYEBOLT	2
17	480-04-00022	STRIKER BRACKET	1
18	480-04-00023	INSULATING STRIP (FRONT)	1
19	480-04-00024	INSULATING STRIP (SIDE)	1
20	480-04-00025	SEALING ARM (LH)	1
21	480-04-00027	BALANCE WEIGHT BRACKET	2
22	480-04-00028	ARM JOINING BLOCK	1
23	480-04-00029	SEALING ARM COVER	1
24	A900-01-081	COLLAR	2
25	A900-03-819	M8 X 12 BUTTON HEAD SCREW	8
26	A900-04-142	M10 NYLOC NUT	2
27	A900-19-090	SPRING	2
28	A900-19-091	SPRING (ARM RETURN)	1
29	B842-62-030	NYLON SCREW INSULATOR	4
30	B944-95-002	FRONT SEALING WIRE	1
31	B944-95-002	SIDE SEALING WIRE	1

ELECTRICAL PARTS LAYOUT

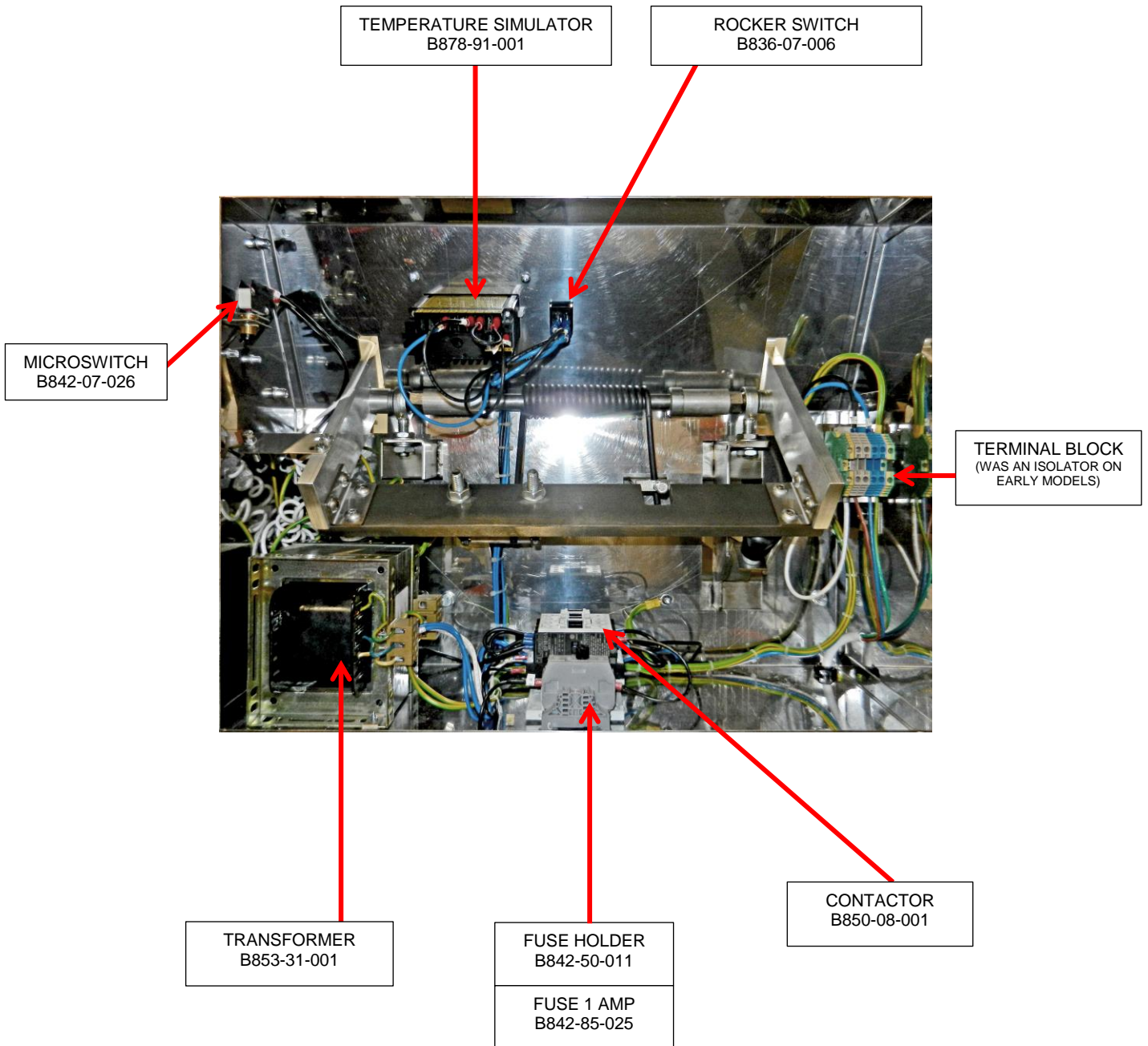

VIEWED FROM REAR WITH DOOR OPEN.
DISCONNECT FROM MAIN POWER SUPPLY BEFORE OPENING.

MANDRELL PARTS

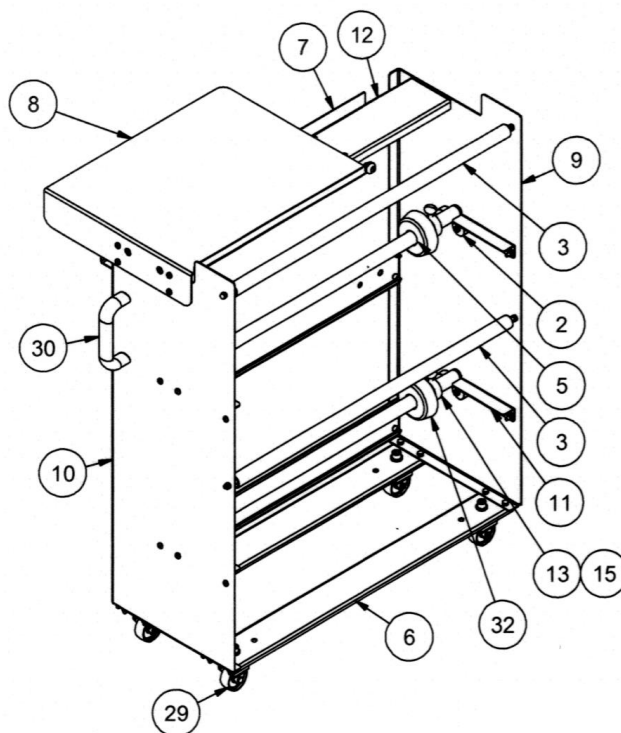

ITEM	PART NUMBER	DESCRIPTION	QTY
1	200-02-00017	BUTTON	1
2	200-02-00018	SHAFT REST	8
3	480-08-00008	FILM ROLLER	2
4	480-08-00010	SPINDLE FOR FILM ROLLER	2
5	480-08-00016	MANDREL	2
6	480-08-00022	CROSS PIECE - TWO MANDREL	5
7	480-08-00024	GUIDING BRKT	1
8	480-08-00025	PLATFORM 2	1
9	480-08-00026	BACK PANEL – TWO MANDREL	1
10	480-08-00027	FRONT PANEL – TWO MANDREL	1
11	480-08-00028	SUPPORT BRKT	4
12	480-08-00029	TOP BRACE	1
13	A900-01-326	COLLAR	4
29	A900-20-074	CASTOR	4
30	A900-27-214	HANDLE	1
NOT SHOWN	A900-27-218	POLYTHENE END CAP	4
NOT SHOWN	A900-35-149	FILM CONE	4

FAULT TRACING TABLE

FAULT	CAUSE	ACTION
Wires burning out	<p>Wires shorting on frame. Worn insulating strips. Excessive heat setting used. Faulty simulator. Faulty contactor, wires heat as soon as m/c is turned on.</p>	Replace faulty items.
No heat on wire with power "ON" neon healthy.	<p>1 amp control fuse blown. Broken supply wire. Bad earth termination.</p> <p>Heat "ON" switch not triggering. Faulty contactor.</p> <p>Faulty transformer.</p> <p>Faulty simulator.</p>	<p>Replace. Replace. Check, ensure the wires are clean and properly clamped. Adjust actuating screw or replace switch. Check coil. Manually depress coil with screwdriver. If centre does not move, change contactor. Check and replace if necessary. Check and replace if necessary.</p>
Neon light dims when operating machine.	Poor neutral return.	Check supply neutral. Poor connection in supply plug.
Fuse blows in supply plug.	<p>High resistance in earth return - broken earth wire. Seal wire or clamp screw shorting on arm. Insulation strip missing. Supply wire bare and shorting to frame. Short circuit in control console. See also "Wires burning out".</p>	<p>Look for break in wire.</p> <p>Look for burn marks.</p>

FAULT	CAUSE	ACTION
Wires too hot on lowest simulator setting.	Faulty simulator	Change simulator.
Only one wire heats up.	Bad earth connection. Broken supply lead.	Check both.
Seal Pad strips burnt out.	Continued use of excessive heat or failure to replace tape when necessary.	Change Seal Pads.
Pack seal bursts open.	Dirty seal area. Dirty seal wire. Pack too tight in film. Insufficient clamp pressure.	Change tape. Clean wires. Allow more slack. Increase pressure.
Power switch "ON" but neon does not light.	No fault Power supply is faulty.	Ensure power supply is "ON" Check fuse in plug, wiring and supply.
Fault remains.	Neon has failed, machine working.	Replace switch.
Film cuts off but fails to weld.	Tension on film does not permit seal during cut-off.	Relax tension on film when sealing.
Seal wire insulation strip badly burnt.	Continued use of excessive heat. Maintenance schedule not followed.	Replace insulation strips.



Queensway,
Swansea West Industrial Estate,
Swansea.
SA5 4EB UK

Tel. 01792 561234
Fax. 01792 561016

email: spares@monoequip.com
Web site: www.monoequip.com

Spares +44(0)1792 564039