

[www.monoequip.com](http://www.monoequip.com)

In the event of an enquiry please quote these serial numbers.

Enter **Serial Nos.** here.

DECK 1
DECK 2
DECK 3
DECK 4
DECK 5
FAN (IF FITTED)



# MODULAR DECK OVEN

## OPERATING AND MAINTENANCE MANUAL

### ECOTOUCH CONTROL

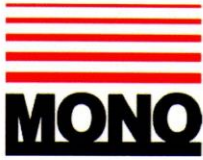

## DECLARATION OF CONFORMITY

We hereby declare that this machine complies with the essential health and safety requirements of :-

- The Machinery Directive 2006 / 42 / EC
- The Low voltage Directive 2006 / 95 / EC
- The requirements of the Electromagnetic Compatibility Directive 2004 / 108EC, 91 / 263 / EEC, 92 / 31 / EEC
- The General Safety of Machinery and food processing Standards applicable
- Materials and Articles intended to come into contact with food - Regulation (EC) No. 1935 / 2004
- Good manufacturing practice for Materials intended to come into contact with food - Regulation (EC) No. 2023 / 2006

<b>Signed</b>	
G.A. Williams – Quality Manager	

<b>Date</b>	
-------------	--

<b>Machine FG Code.</b>		<b>Machine Serial No.</b>	
-------------------------	--	---------------------------	--

A technical construction file for this machine is retained at the following address:

**MONO EQUIPMENT**  
Queensway,  
Swansea West Industrial Park,  
Swansea  
SA5 4EB  
UK

**MONO EQUIPMENT** is a business name of **AFF GROUP Ltd**  
Registered in England No.3872673 VAT registration No.923428136

Registered office: Unit 35,  
Bryggen Road,  
North Lynn Industrial Estate,  
Kings Lynn Norfolk,  
PE30 2HZ

## **IMPORTANT NOTES**

- **TO REDUCE RISK OF FIRE OR ELECTRIC SHOCK, DO NOT REMOVE COVERS (OR BACK SHEETING). NO USER SERVICEABLE PARTS INSIDE. REPAIR SHOULD BE DONE BY AUTHORISED PERSONNEL ONLY.**
- **FAILURE TO ADHERE TO THE CLEANING AND MAINTENANCE INSTRUCTIONS DETAILED IN THIS MANUAL COULD AFFECT THE WARRANTY OF THIS MACHINE.**
- **THE OVEN SHOULD ONLY BE USED FOR BAKING BREAD, PASTRIES AND CAKES**
- **SOME SECTIONS OF THIS MANUAL ARE FOR ENGINEERS ONLY AND THE CUSTOMER SHOULD NOT ATTEMPT TO MAKE ALTERATIONS.**
- **BEWARE OF HOT SURFACES.  
DO NOT TOUCH OVEN FRONT OR DOOR WITH BARE SKIN.**

As it is our policy to improve our machines continuously, we reserve the right to change specifications without prior notice.

---

# CONTENTS

---

<b>Section - 1.0</b>	<b>Introduction</b>
<b>Section - 2.0</b>	<b>Overall Dimensions</b>
<b>Section - 3.0</b>	<b>Specifications</b>
<b>Section - 4.0</b>	<b>Safety</b>
<b>Section - 5.0</b>	<b>Installation</b>
<b>Section - 6.0</b>	<b>Isolation</b>
<b>Section - 7.0</b>	<b>Cleaning</b>
<b>Section - 8.0</b>	<b>Operating Conditions</b>
<b>Section - 9.0</b>	<b>Principles Of Operation</b> (and baking advice)
<b>Section - 10.0</b>	<b>TOUCH SCREEN OPERATION</b>
	<b>-Basic operation-</b>
10-1.0	<b>Bake using “FAVOURITES” menu</b>
10-2.0	<b>“MANUAL” menu</b>
10-3.0	<b>“PROGRAMMES” menu</b>
10-4.0	<b>Creating a program</b>
10-5.0	<b>7-Day timer</b>
10-6.0	<b>Settings</b>
	Time and date
	Settings – General level
	Settings explained – General level
	Settings – High level
	Settings explained – High level
	Default Passcodes
10-7.0	<b>Using the USB port</b>
10-8.0	<b>Diagnostics</b>
<b>Section - 11.0</b>	<b>Troubleshooting</b>
<b>Section - 12.0</b>	<b>Service Information</b>
	Replacing light bulbs
<b>Section - 13.0</b>	<b>Spares Information</b>
<div style="border: 1px solid red; padding: 10px; margin: 10px auto; width: fit-content;"><b>THIS SECTION IS FOR ENGINEERS ONLY AND THE CUSTOMER SHOULD NOT ATTEMPT TO MAKE ALTERATIONS.</b></div>	
<b>Section - 14.0</b>	<b>Electrical Information</b>
<b>Section - 15.0</b>	<b>WARNING and INFORMATION LABELS</b>

# 1.0 INTRODUCTION

---

The electric modular Deck Oven is an easy to use practical, good-looking oven, giving an excellent heat recovery rate and an even bake across a wide range of bread and confectionery products.

- Good looking and totally reliable

Conceived with the no nonsense requirements of both the independent and in-store baker in mind, and designed to visually please as well as give reliable service for many years. This oven will more than satisfy the most discerning customer.

- Top quality specification

The external and internal contact surfaces are stainless steel.

Each modular deck is fitted with durable reinforced one-piece tiles, and an increase in high-grade insulation and high temperature ceramic sealant, makes the oven more efficient.

The oven comes with a patented integral steaming system, which reduces energy consumption and the overall size of the oven. The system produces real steam with the advantages of spray steam. Pre-steam is also available to reduce the affects of long loading times.

No drainage is required.

Ecotouch ovens are supplied with **TOUCH** displays for the user-friendly control panels. This can show pictures of product types or program numbers that have been set by the user. When not being used, the screen can show your company logo. A voice prompt facility is also available for the basic instructions like “Bake over”.



The lights are low voltage, sealed from the chamber and easily accessed from outside the oven.

Fitted with a choice of hinged easy to clean glazed doors (using low energy-loss reflective glass for high visibility) or metal doors, means low energy consumption and the high kW rating gives good recovery.  
(0-100% heating available both top and bottom)

As it is our policy to improve our machines continuously, we reserve the right to change specifications without prior notice.

# 2.0 OVERALL DIMENSIONS

ALL DIMENSIONS ARE APPROXIMATE

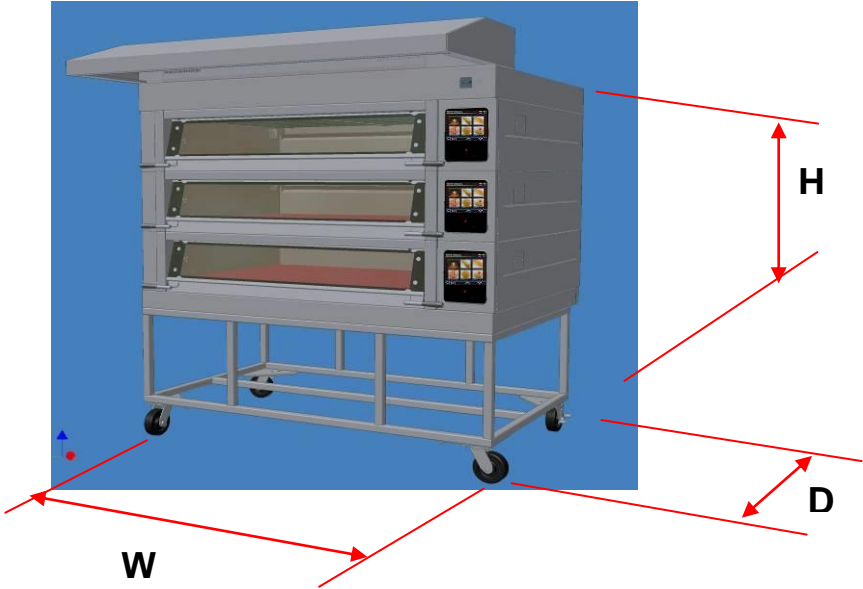

5 DECK oven ..... **H** = 2135mm

4 DECK oven ..... **H** = 2020mm

3 DECK oven ..... **H** = 2020mm

Ovens available with 1,2,3, 4, and 5 modules

812mm deep modules ..... **D** = 1300mm

3 Tray wide oven ..... **W** = 1890mm

2 Tray wide oven ..... **W** = 1416mm

1 Tray wide oven ..... **W** = 940mm

# 3.0 SPECIFICATIONS

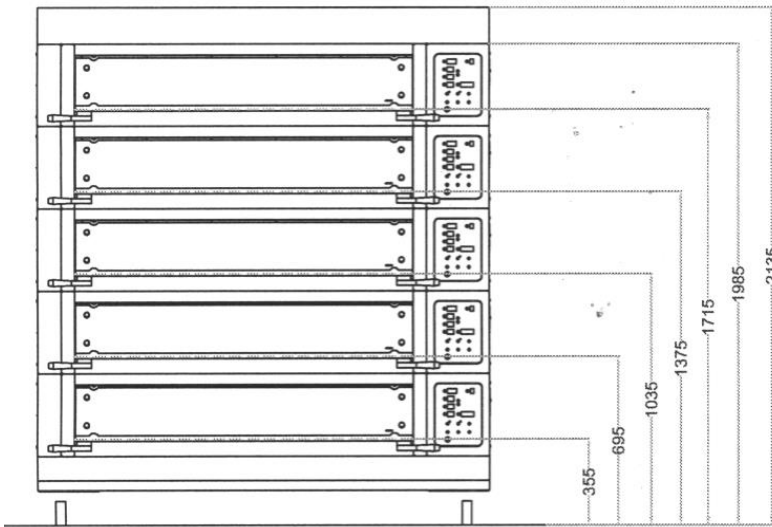

**5 DECK OVEN  
DECK PLATE HEIGHTS**

**4 DECK OVEN  
DECK PLATE HEIGHTS**

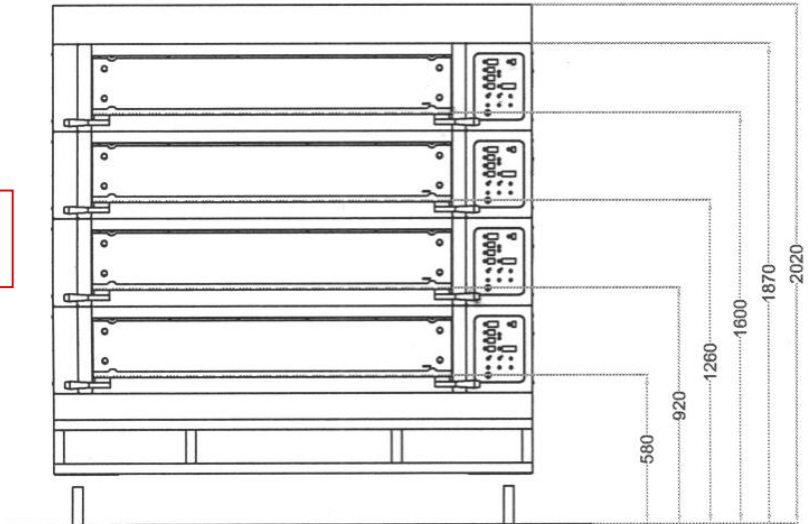

**3 DECK OVEN  
DECK PLATE HEIGHTS**

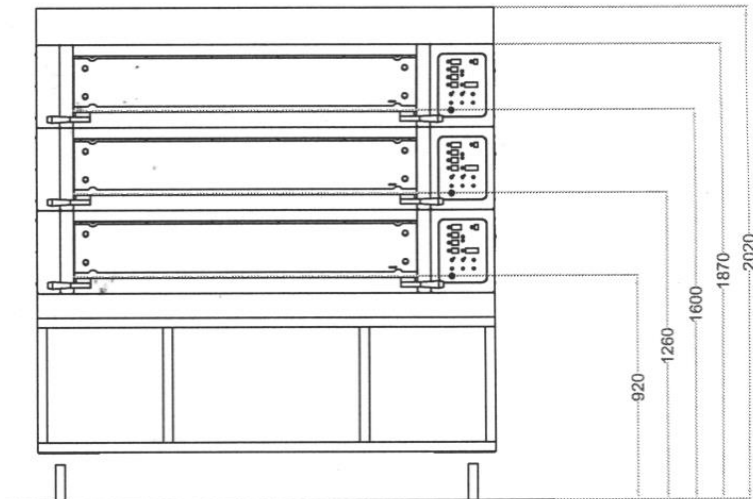

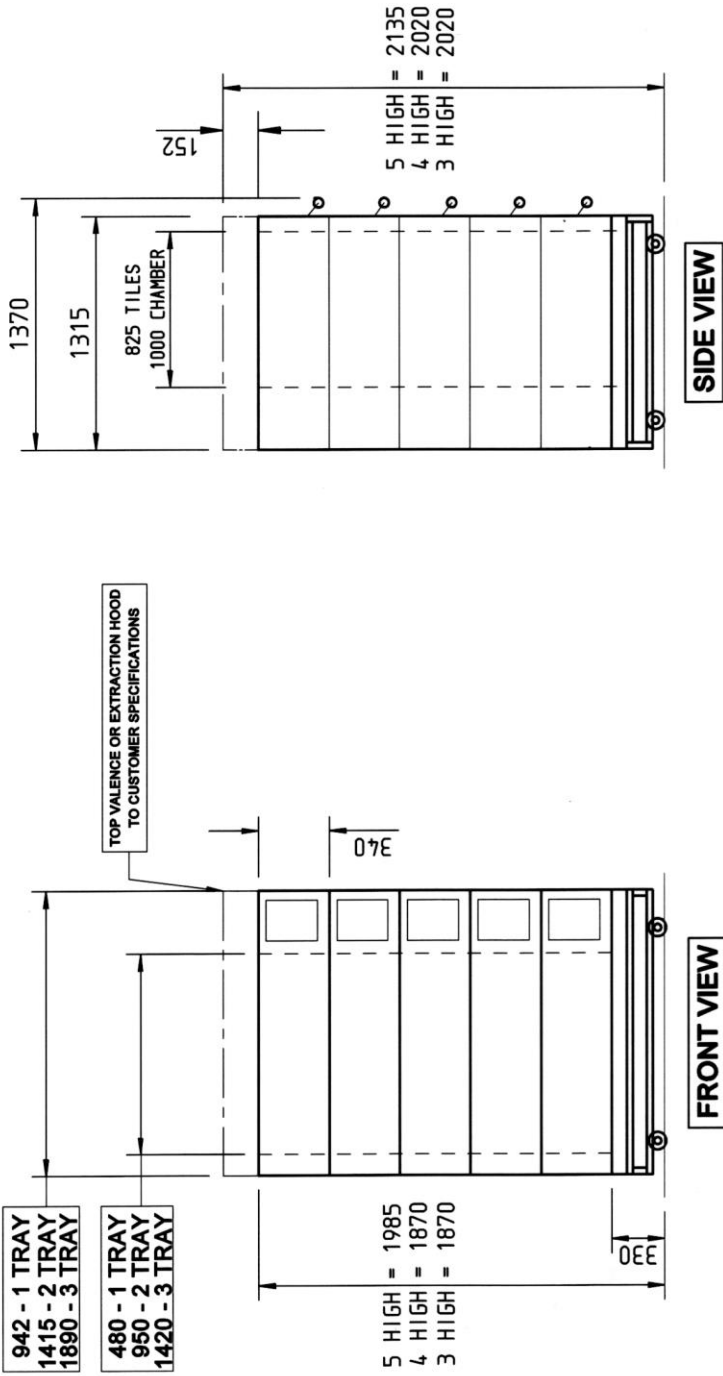

DIMENSIONS IN MILLIMETRES

NOMINAL TRAY WIDTH	EXTERNAL SURFACE AREA	INTERNAL SURFACE AREA	INTERNAL SURFACE TILE AREA	No. OF TRAYS (per deck)				
				609 x 813	24" X 32"	609 x 406	24" X 18"	457 x 762
3 tray	2.48Mtr <sup>2</sup>	1.16Mtr <sup>2</sup>	1.17Mtr <sup>2</sup>	2	4	3	3	
2 tray	1.86Mtr <sup>2</sup>	0.77Mtr <sup>2</sup>	0.78Mtr <sup>2</sup>	1	2	2	2	
1 tray	1.24Mtr <sup>2</sup>	0.39Mtr <sup>2</sup>	0.48Mtr <sup>2</sup>	1	1	1	1	1

**MONO MODULAR DECK OVEN**



# ELECTRICAL LOADINGS:

- SUPPLY REQUIRED PER MODULAR DECK:

	<u>3 TRAY WIDE</u>	<u>2 TRAY WIDE</u>	<u>1 TRAY WIDE</u>
3 Phase N + Earth, 400V. 50Hz	9.0kW, 13Amp	6.0kW, 9Amp	3.0kW, 5Amp

**NOISE LEVEL:**    Less than 80 Db

## **WEIGHT:**

(ALL WEIGHTS ARE APPROXIMATE)

Total oven weight (Including base frame)	- 2 tray wide, 3 deck	= 1569lbs	(711kg)
	- 3 tray wide, 3 deck	= 2345lbs	(1064kg)
	- 1 tray wide, 3 deck	= TBA	
Weight per oven chamber module	- 2 tray wide	= 421lbs	(191.5kg)
	- 3 tray wide	= 575lbs	(261kg)
	- 1 tray wide	= TBA	
Weight per oven canopy module	- 2 tray wide	= 31lbs	(14kg)
	- 3 tray wide	= 38lbs	(17kg)
	- 1 tray wide	= TBA	
Weight per fan module	- 2 tray wide	= 62lbs	(28kg)
	- 3 tray wide	= 62lbs	(28kg)
	- 1 tray wide	= TBA	
Weight of product (max) per deck	- 2 tray wide	= 86lbs	(39kg)
	- 3 tray wide	= 131lbs	(60kg)
	- 1 tray wide	= TBA	

## 4.0 SAFETY

---

**All maintenance must be made with the oven disconnected from the power supply and then only by fully trained authorized persons.**

- Check all cover panels, and any pipefittings are securely positioned.
- Check oven door handles are not damaged.
- **Do not operate a deck's steaming system with oven door open.**
- Always use oven gloves when loading or unloading the oven.
- When products are removed from the oven, ensure:
  - (a) Tins are knocked out and stored directly onto a tin storage trolley or rack  
(Do not leave hot tins on the floor or on tables).
  - (b) Trays are put into a rack and the rack is wheeled to a safe cooling area.
- Do not store items on top of the oven.

Beware of hot surfaces. Do not touch oven front or door with bare skin.

- Do not store items behind the oven.
- All operatives must be fully trained
- People undergoing training must be under direct supervision
- The oven should only be used for baking bread, pastries and cakes (for other products please contact your oven supplier)
- No unauthorized modifications should be made to the oven.
- **Do not walk on the roof of the oven**
- **DISPOSAL**  
Care should be taken when the oven comes to the end of its working life. All parts should be disposed of in the appropriate place, either recycling or other means as the law permits at the time.

**NOTE: BAKERY STAFF MUST NOT UNDER ANY CIRCUMSTANCES REMOVE PANELS TO ACCESS ANY PART OF THE DECK OVEN.**

**Panels should only be removed for repairs or maintenance, after isolating oven from power supply, by a Mono maintenance engineer (or other fully trained maintenance contractor)**

**The Bakery Manager or the Bakery Supervisor must carry out the above daily safety checks**

# 5.0 INSTALLATION

## GENERAL

- A hard smooth level floor is recommended on which to position the oven and access for maintenance should be considered.  
*The oven is not designed to be "built in" so sufficient clearance must be left in front of the access panels (right hand side) to allow for servicing.*
- If not chosen as an oven option, it is recommended that an extraction hood be placed above the oven to disperse excess steam and heat, which could have an adverse effect on the bakery ceiling and ambient temperature.

- A wall isolator **must** be available in order to completely isolate the oven.  
**THIS ISOLATOR MUST BE CLEARLY ACCESSIBLE TO THE OVEN OPERATOR**

- A chain retainer should be fitted, that is shorter than the power cables, to protect them from strain if the oven is moved. (Fit to the wall or floor and the base, using hole provided in castor fixing corner plates).
- Installation must be made by a trained authorized engineer and all utilities must conform to all local regulations.
- **The oven must be "run in" as stated in the initial start up instructions.**

## ELECTRICAL CONNECTIONS

- **SUPPLY REQUIRED PER MODULAR DECK:**  
**(One main connection point for all deck supplies at top of oven)**

	<u>3 TRAY WIDE</u>	<u>2 TRAY WIDE</u>	<u>1 TRAY WIDE</u>
3 Phase N + Earth, 400V. 50Hz	9.0kW, 13Amp	6.0kW, 9Amp	3.0kW, 5Amp

# **IMPORTANT OPERATION**

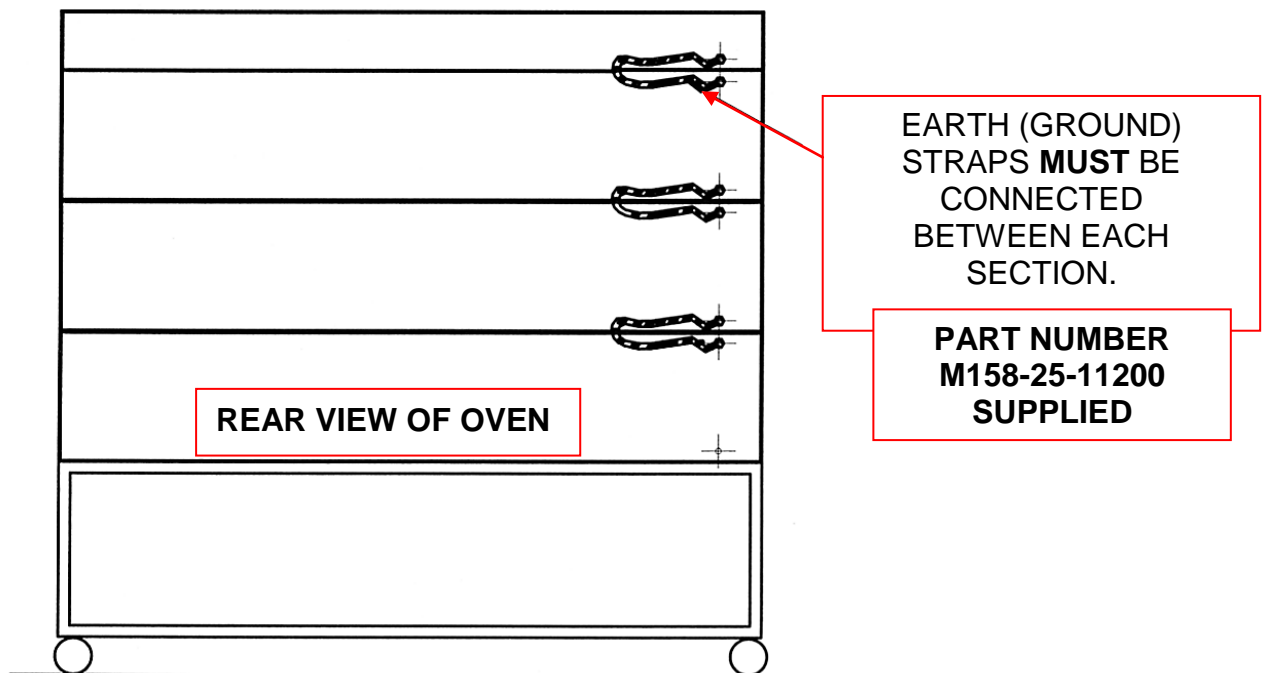

# **WATER SUPPLY REQUIREMENTS**

**The set up procedure on the next page must be followed to allow the steaming system to function correctly**

- All ovens with steam require a  $\frac{3}{4}$ " BSP hot or cold water supply at a pressure of 2 - 3 bar (29 – 44 psi).
- Only one water supply is required per oven. This should comply with local water regulations.
- A manifold supplies all decks from one connection point.
- For proper operation of the steam system it is recommended that the water supply follows the following specifications:

**Hardness**                      0-4 grains per gallon

**PH range**                      7.0 to 8.5

**Chloride concentration**      0 –20 ppm

**Consult Mono for proper water filtration system information.**

- No drain is required for this oven.
- **A non-return check-valve is supplied fitted to the water inlet manifold.**

# WATER SYSTEM SETUP PROCEDURE

It is imperative that the water delivery to the deck oven is checked for the steam system to operate correctly

1. Flush out the main feed pipe to be used, until water runs clear and free from debris.
2. Connect main feed to oven.
3. Connect flexible hoses to each deck.
4. Place a container under the test valve.
5. Slowly open test valve fully and with the water flowing check the regulator is set to 0.75 bar. If not adjust using the screw on the regulator.
  - **Never use the oven above this setting**
6. When the pressure has stabilised, shut the test valve.

REPEAT 4,5 AND 6 AT THE END OF INSTALLATION.

**NOTE.** DYNAMIC PRESSURE, NOT STATIC, IS BEING MEASURED.

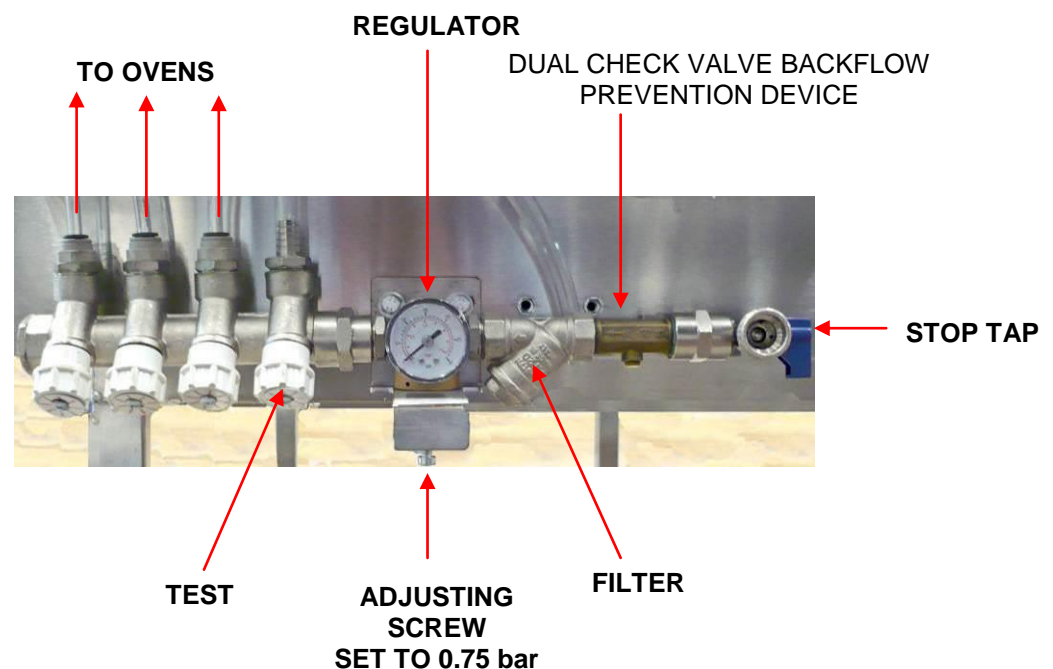

**WATER REGULATOR SET UP**  
LOCATED ON REAR OF OVEN

## Exhaust Connections (IF CANOPY FITTED)

- Ideally an exhaust duct should rise 2 metres above the bakery roof protected from wind and birds by a duct protector.
- It should be of a suitable material to take the high temperatures and humidity expected.
- It should be flexible and easily removable at the oven connection point.  
*This allows the oven to be moved for cleaning when required.*

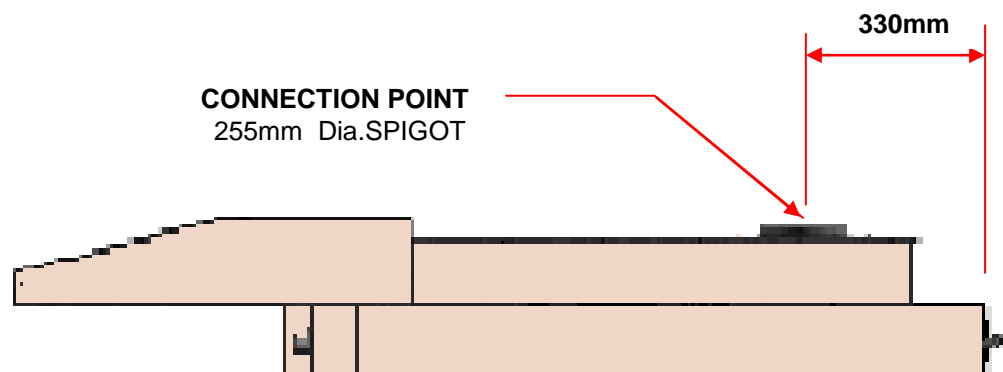
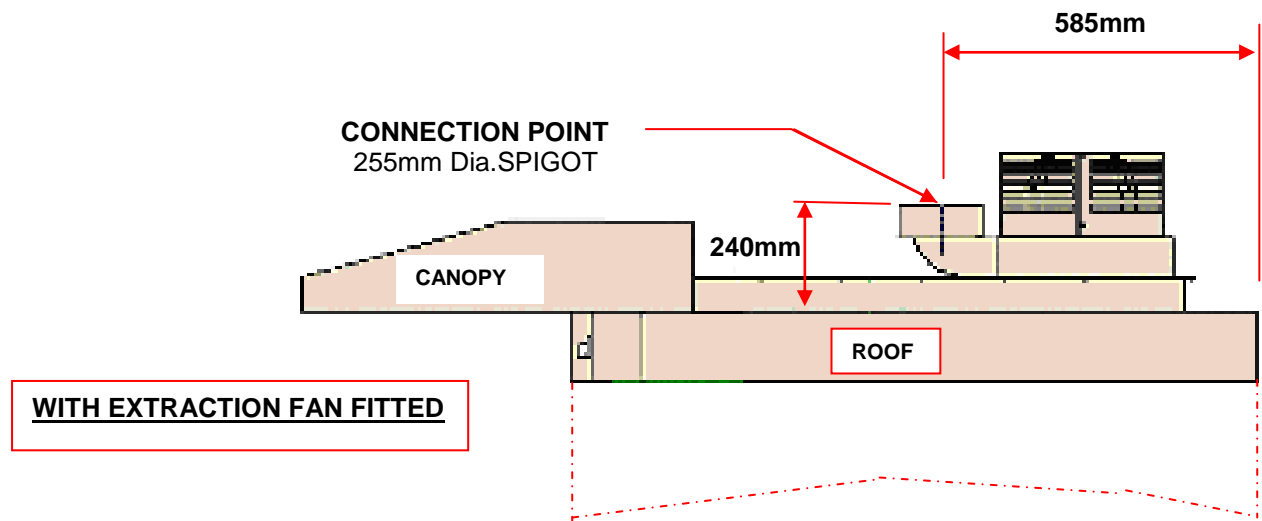

**WITHOUT EXTRACTION FAN FITTED**

# INITIAL START UP

**THIS PROCEDURE MUST BE ADHERED TO FOR THE OVEN WARRANTY TO BE VALID.**

In order for the oven to give good reliable service, the deck tiles must be initially brought up to temperature as stated below.

After this running in period the oven can be used as required.

## Running in procedure

1. Turn the oven on and note the temperature shown.

(This will be the temperature inside the cooking chamber)

2. The temperature needs to rise to 110deg C, at no more than 2deg a minute.  
DO NOT USE BOTTOM HEAT AT ANY TIME.

3. Take the temperature up to 260deg C, at no more than 1deg in 2 minutes.  
THIS WILL TAKE 5 HOURS.

## BAKING TILES -- INSTRUCTIONS FOR FIRST TIME USE

THIS PROCEDURE MUST BE USED FOR THE OVEN WARRANTY TO BE VALID

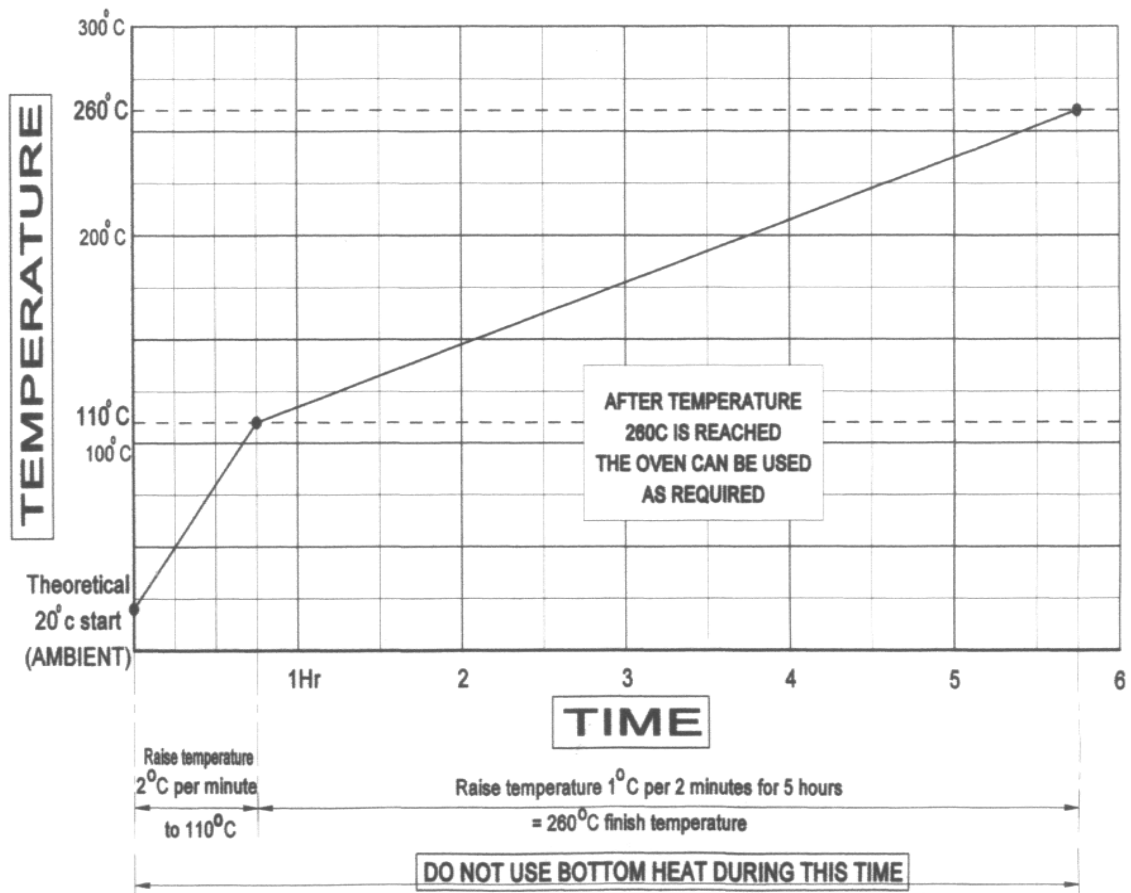



## 6.0 ISOLATION

---

### **WARNING**

**THE “POWER OFF” BUTTON ON THE FRONT OF THE OVEN DOES NOT ISOLATE THE POWER SUPPLY.**

---

**A WALL ISOLATOR MUST BE AVAILABLE IN ORDER TO COMPLETELY ISOLATE THE OVEN.**

**THIS ISOLATOR MUST BE CLEARLY ACCESSIBLE AND KNOWN TO THE OVEN OPERATOR**

---

**TO STOP THE OVEN IN AN EMERGENCY SWITCH OFF AT THE MAIN WALL ISOLATOR**

## 7.0 CLEANING

---

### DAILY CLEANING INSTRUCTIONS

**ISOLATE OVEN FROM MAINS SUPPLY BEFORE CLEANING.**

- After the oven has been allowed to cool, (this could take several hours), sweep any debris out.  
Use a vacuum cleaner with metal attachments (able to take heat) if available.
- Brush down and wipe oven front, back and sides with a damp cloth.
- Spot clean with a damp cloth, which has been soaked in a solution of mild detergent, and hot water, paying particular attention to ensure excess water is not applied around the area of the electrical panels.

**NOTE: TAKE CARE WATER DOES NOT ENTER CONTROL PANEL MOUNTING OR ROOF MOUNTED FAN.**

### WEEKLY CLEANING INSTRUCTIONS

**ISOLATE OVEN FROM MAINS SUPPLY BEFORE CLEANING.**

- Complete daily cleaning as above.
- Scrub oven wheels with a mild detergent and hot water using nylon cleaning brush.
- Ensure the oven roof area is clear of debris and dust build up.  
**(DO NOT STAND ON THE OVEN ROOF)**

## 8.0 OPERATING CONDITIONS ---

- It is recommended that a space of at least 6 feet be left in front of the oven for ease of operation and safety.
- Bakery utensils must not be used to operate the control panel buttons.

## 9.0 PRINCIPLE OF OPERATION ---

**NOTE:** *FOR OVEN TEMPERATURE SETTINGS,  
REFER TO YOUR OWN COMPANY'S RECIPE MANUAL  
PLEASE ALSO REFER TO THE BAKING ADVICE ON THE NEXT PAGE*

Products are baked in an insulated heated chamber.

The **temperature** is regulated by a thermocouple having a read-out on the front control panel.

Baking heat is radiant with top and bottom heat being adjusted by means of separate controls. This enables heat to be “balanced” according to product requirement.

**STEAM** is provided from an integral steam unit, and is introduced into the chamber on demand. This is automatically controlled by the programmed parameters.

**Once steamed the oven will not steam again until the steam unit has recovered heat, typically 3-8 minutes depending on the amount of steam selected.**

---

All ovens are fitted with a **steam damper** that evacuates steam humidity into a vent at the side of the oven.

# Baking Advice

## For the best results from deck Ovens

### Loading

1. **Do not place the products too close together.** *If the loaves are close to each other after oven spring (expansion), the loaves sides will be soft and may collapse on cooling.*
2. **Place the product evenly within the oven.** *Product bunched together will be paler than those widely spaced.*
3. **Product should not be placed too close to the edge of the tile.** *As it expands towards the front one side of the loaf may enter the cooler air by the door.*
4. **Door opening should be kept to a minimum** *because cold air enters the oven cooling the sidewalls and roof causing the finished product to be lighter locally at the front and wasting heat. If loading times are consistently long you can alter the front top heat to put more heat at the front.*
5. **If the loading takes a long time, product can form a skin,** *which causes an imbalance and a less attractive finish. By using the pre-steam function before loading this can be minimised. This function turns the elements off and injects steam to increase the humidity.*

### Bake settings

1. A good starting point for baking breads in Mono deck ovens is **225C (437F)**  
Top heat 60-65      bottom heat 40.
2. For cookies etc, the heat in the oven can be turned almost off, however it may still be necessary to place the trays with cookies etc onto upturned trays on the oven sole.
3. **Steam** should be kept to a minimum, for energy efficiency, depending on the product and finish. **Times between 9 and 12 seconds should be adequate.**
4. It is a good idea not to focus on the temperature recovery this can vary from oven to oven.

## **Is the product baked in the time and to the quality you require?**

*Below are some tips for modifying the bake so you get the product that you require.*

- **If your product is light on top.**

Either decrease the bottom heat and extend bake time or increase the top heat.

- **If the product sides are pale and the top dark.**

Make sure the products are spaced well apart, drop the top heat and extend the bake time.

- **If the bake time is too long.**

First increase the top heat to speed recovery.

If this does not give sufficient savings increase the bake temperature.

- **To thicken the crust**

Set the damper to open longer. Different ovens will require different lengths of time.



## 10.0 TOUCHSCREEN OPERATING INSTRUCTIONS

# BASIC OPERATION

ALL OPERATIONS ARE ACTIVATED BY TOUCHING AREAS ON THE SCREEN, WHICH WILL PASS YOU ON TO THE NEXT INFORMATION PANEL.

DO NOT USE EXCESSIVE FORCE.  
(THE PRESSURE REQUIRED TO OPERATE THE PANEL, CAN BE ALTERED IN THE SETTINGS SECTION)

TOUCH THE SCREEN ON THE AREA YOU REQUIRE TO ACTIVATE

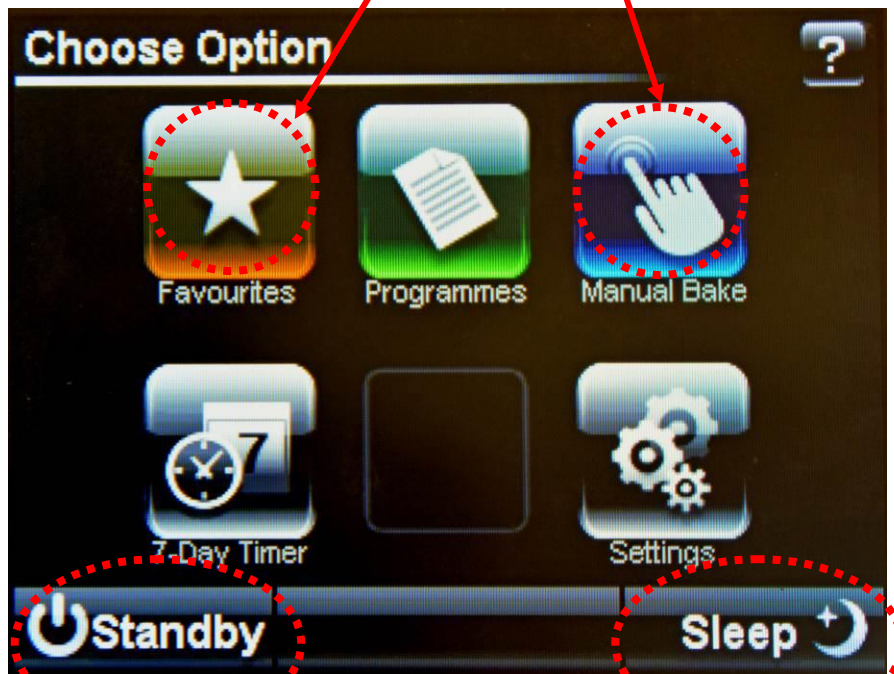

**STANDBY**  
THE OVEN TURNS OFF.  
TOUCH THE SCREEN TO GO TO THE OPTION SCREEN.

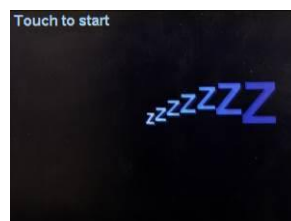

**SLEEP**  
THE OVEN STAYS AT 100c AND HEATS TO LAST PROGRAM TEMPERATURE WHEN THE SCREEN IS TOUCHED. OPTION SCREEN THEN SHOWS.

# 10 -1 BAKING USING “FAVOURITES” MENU

TOUCH TO OPEN THE FAVOURITES SELECT SCREEN



OPTION SCREEN

TOUCH THE NAME OF THE PRODUCT REQUIRED



SELECT SCREEN

TOUCH THE “FULL LOAD” OR “HALF LOAD” AS REQUIRED.  
(THIS ONLY APPEARS IF HALF LOAD IS SAVED IN THE PROGRAM)

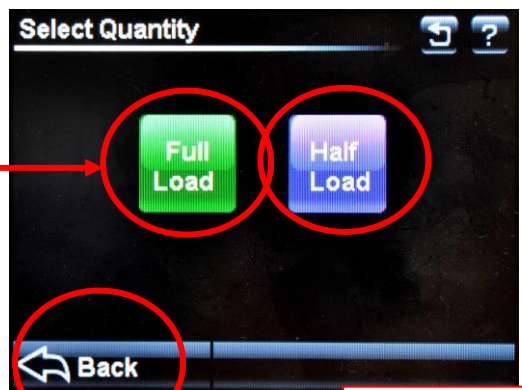

LOAD SCREEN

TO RETURN TO THE PREVIOUS SCREEN TOUCH THE “BACK” BUTTON AT ANY TIME



IF THE OVEN IS NOT UP TO TEMPERATURE IT WILL SHOW THE HEATING SCREEN.

**WAIT FOR THE OVEN TO REACH TEMPERATURE**

IF THE OVEN IS TOO HOT FOR THE TEMPERATURE CHOSEN, THE SCREEN WILL TELL YOU TO OPEN THE DOOR TO AID COOLING.



HEATING SCREEN

WHEN OVEN IS AT THE CORRECT TEMPERATURE THE "READY" SCREEN WILL SHOW.

1. OPEN DOOR AND LOAD PRODUCT.
2. CLOSE THE DOOR FULLY.
3. TOUCH "START"

TIP  
TO HELP TO KEEP THE OVEN HOT, TRY NOT TO KEEP THE DOOR OPEN MORE THAN NEEDED

4



READY SCREEN

**BAKE IN PROGRESS SCREEN**

THIS SCREEN WILL SHOW WHILE THE PRODUCT IS BAKING

**ACTUAL OVEN TEMPERATURE**  
This will rise and fall round the set temperature

SET TEMPERATURE

TEMPERATURE PROFILE BAR

BAKE TIME PROGRESS BAR



BAKE TIME LEFT

NOTE  
The actual temperature shown will rise and fall above and below the set temperature as the oven cools and reheats. *This is not a fault*

**BAKE OVER SCREEN**

**5**

AT THE END OF THE BAKE TIME, A SOUNDER WILL BE HEARD AND "BAKE OVER" WILL FLASH. TOUCH "**STOP**" AND OPEN THE DOOR TO REMOVE THE PRODUCT.

TO KEEP THE OVEN BAKING FOR EXTRA MINUTES THE "+ 2 MIN" BUTTON CAN BE TOUCHED.  
(This time can be altered in set up)



**TOUCHING "VIEW" BUTTON DURING A BAKE**

TOUCHING "**VIEW**" BUTTON DURING A BAKE WILL SHOW THE SETTINGS FOR THE BAKE IN PROGRESS.

TOUCH "**CANCEL**" TO GO BACK TO THE PREVIOUS SCREEN.

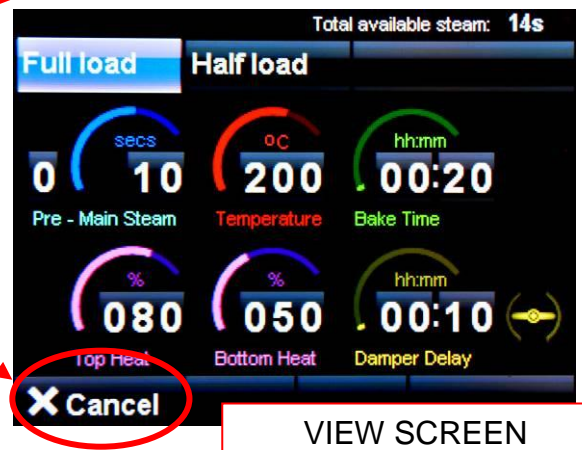

**VIEW SCREEN**

# 10 - 2 BAKING USING “MANUAL” MENU

TOUCH TO OPEN  
MANUAL BAKE  
SCREEN



OPTION SCREEN

## SET BAKE TIME AND TEMPERATURE

**SET TOP AND  
BOTTOM HEAT**  
TOUCH POSITION ON  
THE SCREEN TO  
ACTIVATE THE  
KEYBOARD SCREEN.  
KEY IN REQUIRED  
SETTING AND  
TOUCH “OK”



MANUAL BAKE SCREEN

**SET BAKE TEMPERATURE**  
TOUCH TEMPERATURE ON THE  
SCREEN TO ACTIVATE THE KEYBOARD  
SCREEN.  
KEY IN REQUIRED TEMPERATURE AND  
TOUCH “OK”

**SET BAKE TIME**  
TOUCH TIME ON THE SCREEN TO  
ACTIVATE THE KEYBOARD SCREEN.  
KEY IN REQUIRED TIME AND  
TOUCH “OK”



**NOTE:**  
TIME DOES NOT HAVE TO BE SET IN MANUAL MODE. (ONLY TEMPERATURE)  
WHEN “START” IS PRESSED, THE TIME WILL COUNT UP INSTEAD OF DOWN.  
TOUCH “STOP” TO FINISH THE BAKE.

# USE STEAM TIME AND DAMPER IF REQUIRED

**STEAM** **4**

TOUCH AND HOLD FOR THE TIME (SECONDS) STEAM IS REQUIRED.  
(THIS CAN BE USED BEFORE OR DURING THE BAKE)

**DAMPER** **5**

TOUCH TO OPEN THE DAMPER DURING THE BAKE.  
(SYMBOL SHOWS GREEN)

TOUCH TO CLOSE THE DAMPER.  
(SYMBOL SHOWS RED)

MANUAL BAKE SCREEN 2



**CANCEL**

TOUCH AT ANYTIME TO GO BACK TO THE SETTING SCREEN.

**START** **6**

TOUCH "START" TO START BAKE



**STOP** **7**

TOUCH "STOP" WHEN END OF BAKE BUZZER SOUNDS OR WHEN REQUIRED IF NO TIME WAS ENTERED

# SAVE (KEEP) MANUAL PROGRAM, IF REQUIRED



MANUAL BAKE SCREEN 3

## SAVE SETTINGS

IF NO TIME WAS ENTERED AT THE START OF THE BAKE, WHEN STOP IS TOUCHED "SAVE" WILL APPEAR AT THE BOTTOM OF THE SCREEN. "SAVE" CAN BE TOUCHED AND AN OPTION SCREEN WILL APPEAR.

7

TOUCH "ADD TO FAVOURITES" OR "SAVE AS"

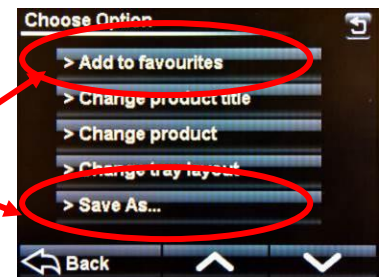

USE KEYBOARD TO TYPE THE REQUIRED NAME AND TOUCH "SAVE"



NOTE: In manual mode, only one operation of the steam or damper is saved.

# 10 - 3 BAKING USING “PROGRAMMES”

**NOTE :** THIS COVERS TWO VERSIONS OF FIRMWARE. (THE OVEN IS PRE-SET TO SHOW ONLY ONE OF THEM).

1. **PICTORIAL** VERSION SHOWS CHOICES OF PRODUCT CATERGORIES
2. **NUMERICAL** VERSION SHOWS RANGES OF PROGRAM NUMBERS.

TOUCH TO OPEN  
“CATEGORY” or  
“PROGRAM CHOICE”  
SCREEN

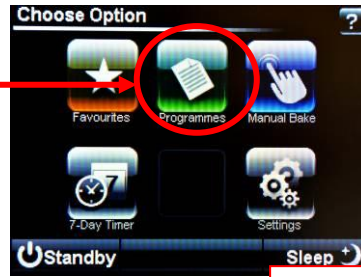

OPTION SCREEN

TOUCH THE TYPE OF  
PRODUCT OR PROGRAM  
RANGE CHOICE WANTED  
AND “SELECT” SCREEN  
OPENS

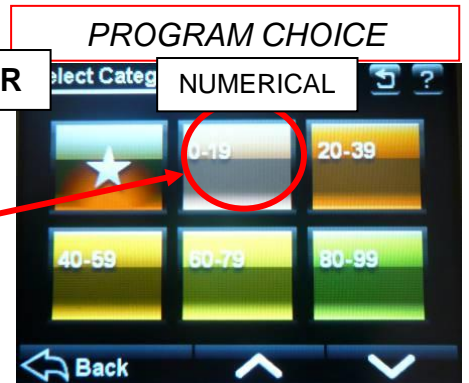

MORE CHOICES

TOUCH THE  
NAME OR NUMBER OF  
THE PRODUCT  
REQUIRED

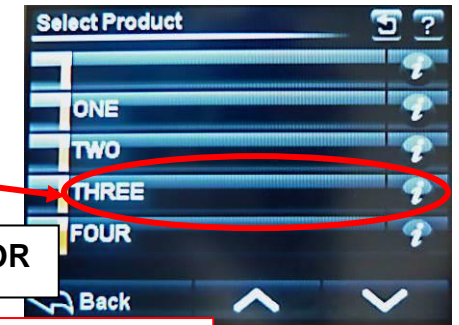

SCROLL DOWN FOR MORE PRODUCTS IF AVAILABLE

SELECT SCREEN

TOUCH THE  
“FULL LOAD” OR  
“HALF LOAD” AS  
REQUIRED.  
  
(THIS ONLY APPEARS IF HALF  
LOAD IS SAVED IN THE PROGRAM)



LOAD SCREEN

TOUCH THE “BACK”  
BUTTON AT ANY TIME  
TO RETURN TO THE  
PREVIOUS SCREEN

IF THE OVEN IS NOT UP TO TEMPERATURE IT WILL SHOW THE HEATING SCREEN.

**WAIT FOR THE OVEN TO REACH TEMPERATURE**

IF THE OVEN IS TOO HOT FOR THE TEMPERATURE CHOSEN, THE SCREEN WILL TELL YOU TO OPEN THE DOOR TO AID COOLING.



HEATING SCREEN

WHEN THE OVEN IS AT THE CORRECT TEMPERATURE, THE "READY" SCREEN WILL SHOW.

1. OPEN DOOR AND LOAD PRODUCT.
2. CLOSE THE DOOR FULLY.
3. TOUCH "START"

*TIP*  
TO HELP TO KEEP THE OVEN HOT, TRY NOT TO KEEP THE DOOR OPEN MORE THAN NEEDED

5



READY SCREEN



THIS SCREEN WILL SHOW WHILE THE PRODUCT IS BAKING

ACTUAL OVEN TEMPERATURE

SET TEMPERATURE

TEMPERATURE PROFILE BAR

BAKE TIME PROGRESS BAR

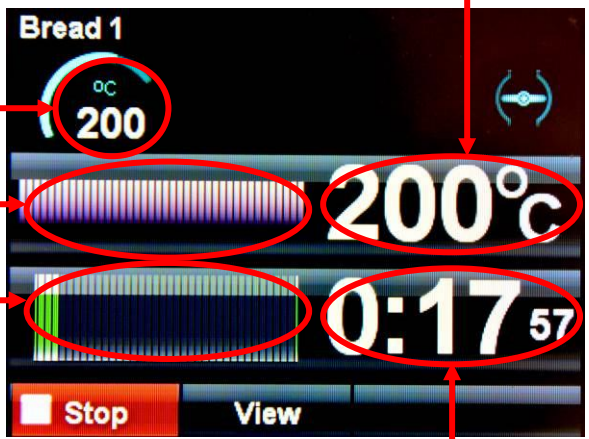

BAKE TIME LEFT

**NOTE**  
The actual temperature shown will rise and fall above and below the set temperature as the oven cools and reheats. This is not a fault

BAKE OVER SCREEN



6

AT THE END OF THE BAKE TIME A SOUNDER WILL BE HEARD AND "BAKE OVER" WILL FLASH. TOUCH "STOP" AND OPEN THE DOOR TO REMOVE THE PRODUCT.

TO KEEP THE OVEN BAKING FOR EXTRA MINUTES THE "+ 2 MIN" BUTTON CAN BE TOUCHED. (THIS TIME CAN BE ALTERED IN SET UP)

TOUCHING "VIEW" BUTTON DURING BAKE



TOUCHING "VIEW" BUTTON DURING BAKE WILL SHOW THE SETTINGS FOR THE BAKE IN PROGRESS. TOUCH "CANCEL" TO GO BACK TO THE PREVIOUS SCREEN.



VIEW SCREEN



# " 10 - 4 CREATING A PROGRAM

TOUCH TO OPEN  
"CATEGORY"  
SCREEN

1



OPTION SCREEN

TOUCH THE TYPE  
OF PRODUCT  
WANTED AND THE  
"SELECT" SCREEN  
OPENS

2



CATEGORY SCREEN

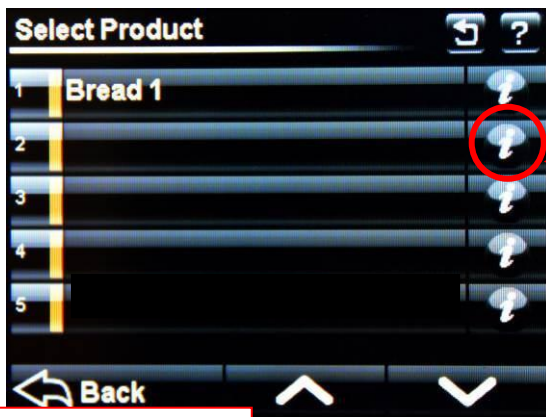

SELECT SCREEN

TOUCH "i" BUTTON  
NEXT TO THE BLANK  
PROGRAM TO OPEN  
NEXT SCREEN

3



INFORMATION SCREEN

TOUCH OPTION TO GO TO  
PASS CODE SCREEN

4

PASS CODE SCREEN

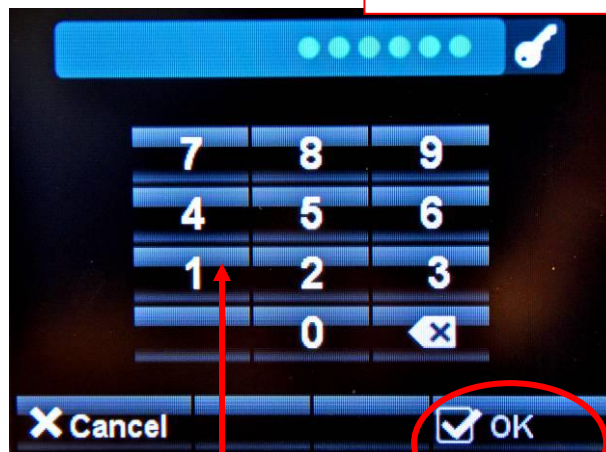

ENTER "SUPERVISOR" PASS CODE AND  
THEN TOUCH OK.  
(DEFAULT CODE = 123456. THIS CAN BE  
CHANGED IN HIGH LEVEL SETTINGS)

5

CHANGE PRODUCT

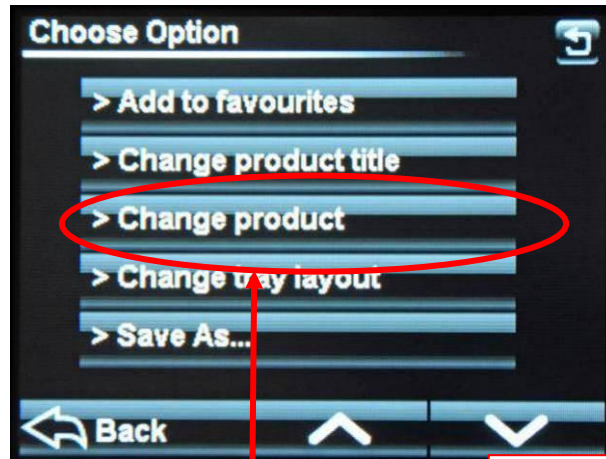

OPTION SCREEN

TOUCH "CHANGE PRODUCT"

6

LOAD TYPE

VALUE CHANGE SCREEN

A screenshot of the "VALUE CHANGE SCREEN" showing various settings. At the top, it says "Total available steam: 14s". There are two load type buttons: "Full load" (highlighted with a red dashed box) and "Half load". Below are six settings, each with a gauge and a numeric keypad: "Pre - Main Steam" (0 to 10 secs), "Temperature" (200 °C), "Bake Time" (00:20), "Top Heat" (030 %), "Bottom Heat" (050 %), and "Damper Delay" (00:10). On the right, there are three buttons: "INCREASE", "OR USE KEYS", and "DECREASE". A numeric keypad is shown to the right of these buttons, displaying "201" and "0". Below the keypad are "Cancel" and "Done" buttons. A red dashed box encloses the numeric keypad and the "INCREASE", "OR USE KEYS", and "DECREASE" buttons. A red arrow points from the "ENTER AMOUNT REQUIRED AND TOUCH DONE" text to the "Done" button. At the bottom, there are "Cancel" and "Save" buttons.

ENTER AMOUNT REQUIRED AND TOUCH DONE

TOUCH EACH ITEM AND CHANGE THE VALUE BY USING THE UP AND DOWN KEYS OR BY USING THE KEY PAD.

TOUCH "HALF LOAD" TO CHANGE TO "HALF LOAD" SETTINGS IF REQUIRED.  
TOUCH "FULL LOAD" TO GO BACK TO "FULL LOAD"

TOUCH "SAVE" WHEN SATISFIED WITH THE SETTINGS.

7

CHANGE TRAY LAYOUT

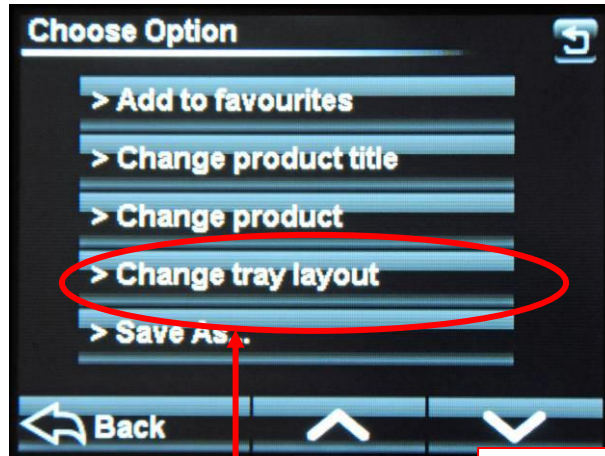

OPTION SCREEN

TOUCH "CHANGE TRAY LAYOUT"

8

TOUCH TO ADJUST  
NUMBER OF PRODUCTS  
ACROSS THE TRAY

TOUCH TO ADJUST  
NUMBER OF PRODUCTS  
DOWN THE TRAY

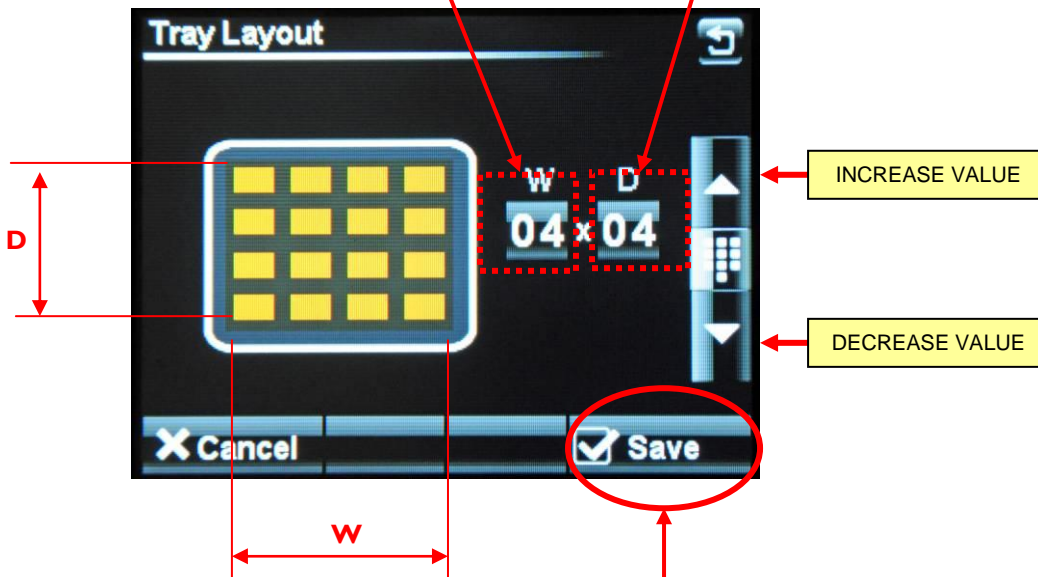

WHEN SATISFIED WITH THE TRAY  
LAYOUT TOUCH SAVE TO RETURN TO  
THE "OPTIONS" SCREEN

9

SAVE

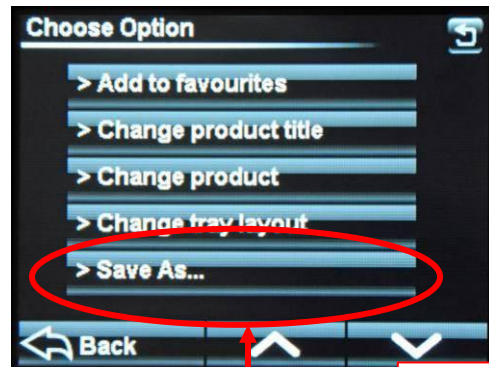

OPTION SCREEN

TOUCH "SAVE AS"

10

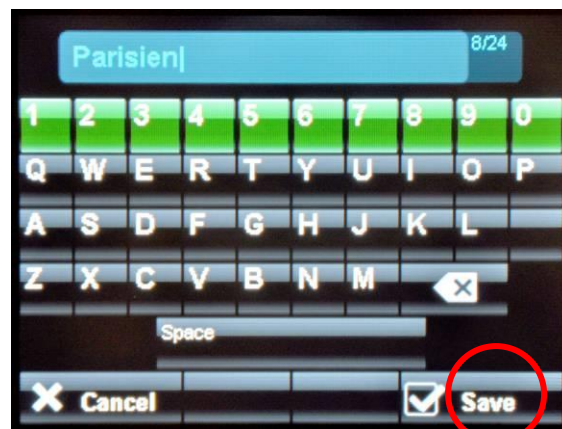

KEYBOARD SCREEN

TYPE IN THE NEW NAME  
AND TOUCH "SAVE"

11

ADD A PRODUCT TO THE FAVOURITES LIST

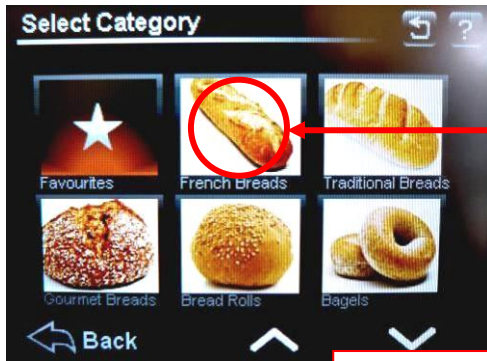

CATEGORY SCREEN

TOUCH THE TYPE OF PRODUCT WANTED AND THE "SELECT" SCREEN OPENS

1



SELECT SCREEN

TOUCH THE "i" (INFORMATION) BUTTON NEXT TO THE PRODUCT YOU WANT AS A FAVOURITE. THIS OPENS THE OPTION SCREEN

2

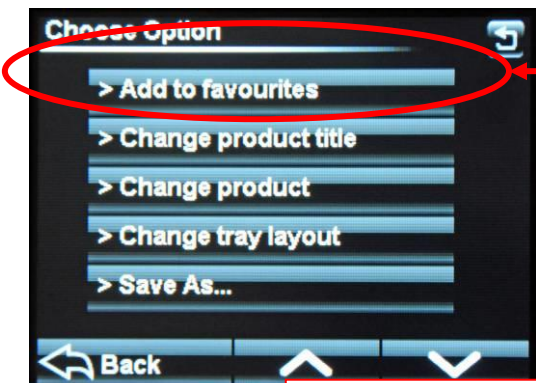

OPTION SCREEN

TOUCH "ADD TO FAVOURITES"  
THE PRODUCT WILL NOW SHOW ON THE FAVOURITES LIST

3

# 10 - 5    SETTING 7-DAY TIMER

TOUCH TO OPEN  
"7-DAY TIMER"  
SCREEN



OPTION SCREEN

CHOOSE DAY

SET "ON" TIME    2

SET "OFF" TIME    4

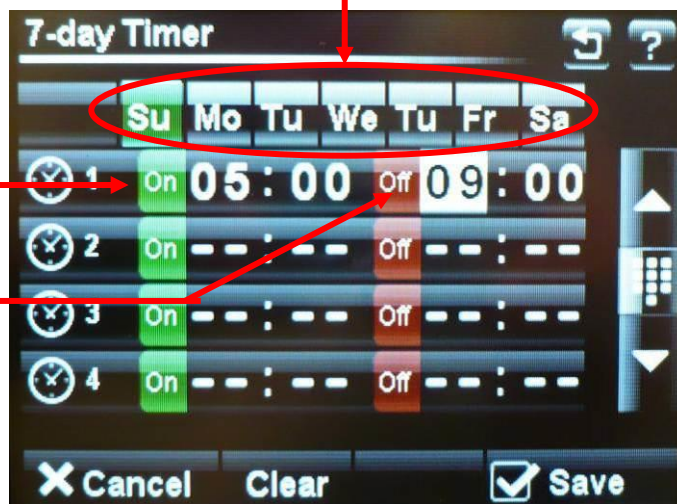

INCREASE VALUE

3

DECREASE VALUE

TIMER SETUP SCREEN

**NOTE**  
Up to four on/off times can be set for each day.  
Touch "**clear**" to clear the settings on the day shown.  
Touch "**save**" to activate the times set.

# 10 - 6 SETTINGS



OPTION SCREEN

TOUCH TO OPEN THE "SETTINGS" SCREEN



PASS CODE SCREEN

ENTER "SUPERVISOR" PASS CODE AND THEN PRESS "OK".  
(DEFAULT CODE = 123456)

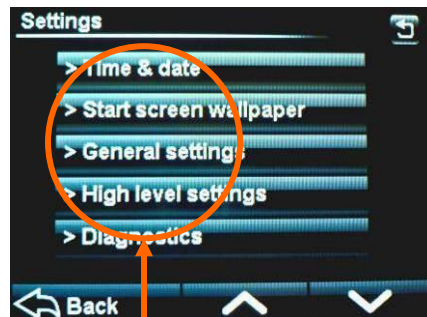

SETTINGS SCREEN

CHOOSE THE SETTING TO ALTER

2



# TIME AND DATE

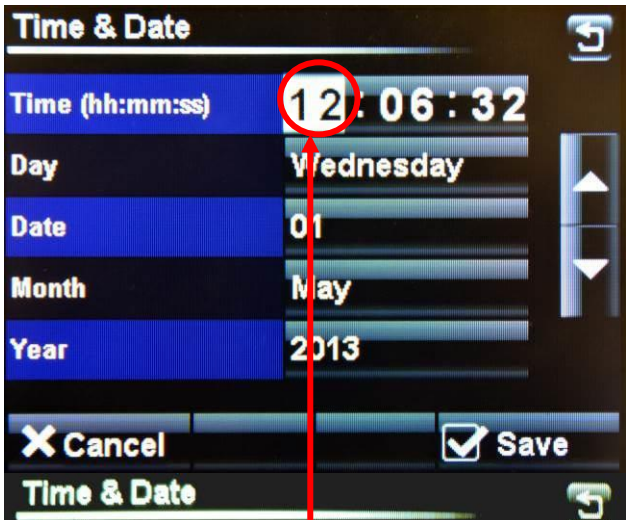

TOUCH THE SCREEN TO HIGHLIGHT THE ITEM TO CHANGE

1

USE THE INCREASE / DECREASE BUTTONS TO ALTER THE SETTINGS

2

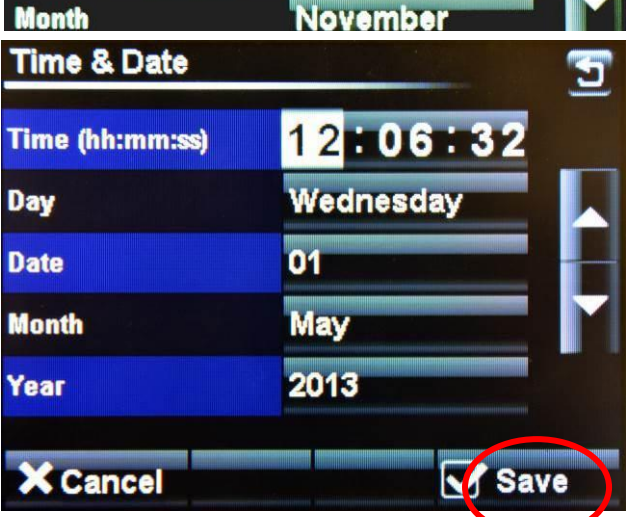

TIME AND DATE SCREEN

WHEN ALL INFORMATION IS CORRECT, TOUCH "SAVE". THIS WILL RETURN TO THE SETTINGS SCREEN

3



SETTINGS SCREEN

# OVEN SETTINGS (GENERAL)

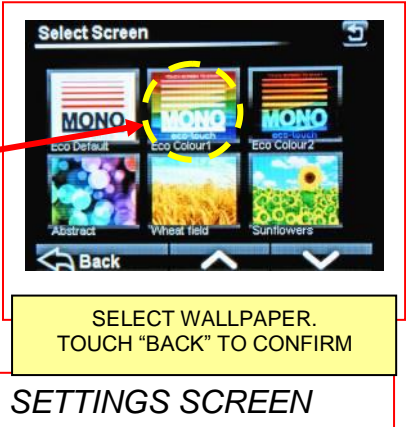
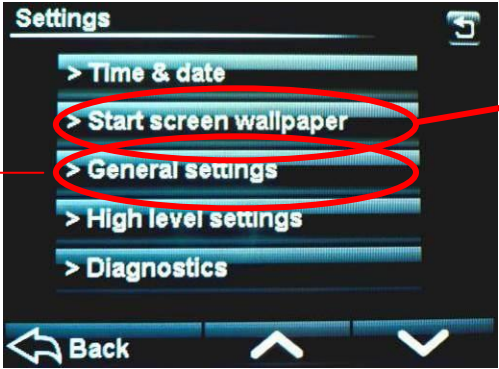

TOUCH "GENERAL SETTINGS" AND THE FOLLOWING SCREEN WILL APPEAR.

SCROLL DOWN TO MOVE THROUGH ALL CHOICES AND ADJUST EACH ONE AS REQUIRED, USING THE ARROW KEYS.

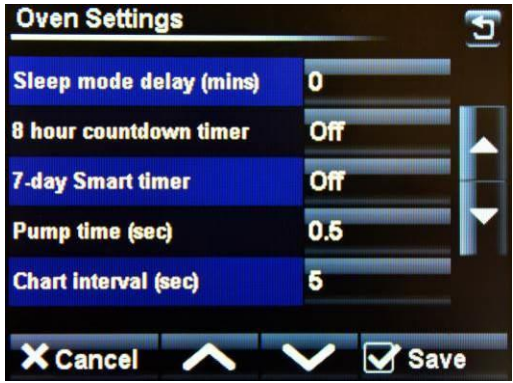
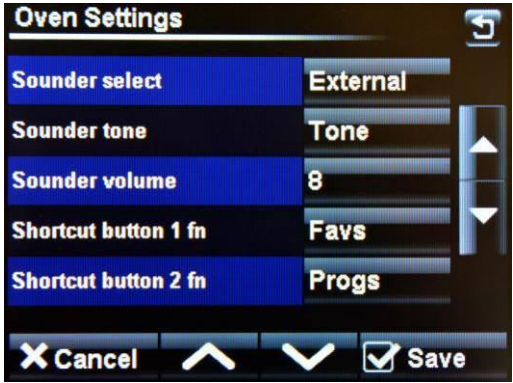
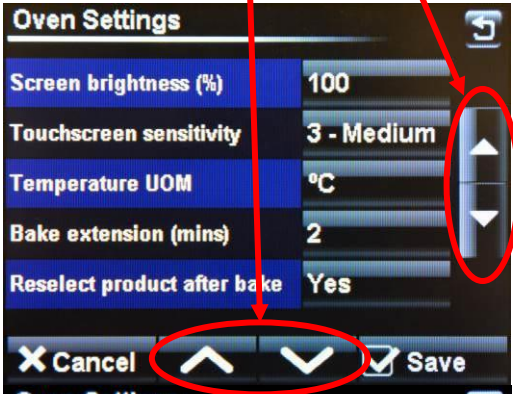

## **OVEN SETTINGS EXPLAINED - GENERAL LEVEL**

### **SCREEN BRIGHTNESS –**

Adjusts the brightness of the viewing screen for user comfort.

### **TOUCHSCREEN SENSITIVITY –**

Adjusts the pressure required to operate the touch screen. (5 settings)

### **TEMPERATURE UNIT OF MEASURE –**

Centigrade (Celsius) or Fahrenheit

### **BAKE EXTENSION (mins) –**

Adjusts the extra time at the end of a bake for each “extra time” button touch. (10mins max)

### **RESELECT PRODUCT AFTER BAKE –**

Resumes with same product program without having to reselect.

### **SLEEP MODE DELAY –**

Oven will go into sleep mode after the set minutes, providing it is up to temperature and has been through at least one bake cycle.

### **8 HOUR COUNTDOWN TIMER –**

After 8 hours the oven gives a warning and then turns off.  
Touch any button for an extra hour if required.

### **7 DAY SMART TIMER –**

ON = 7 day timer function

OFF = Controls set start time depending on existing oven temperature.

### **PUMP TIME (SEC) –**

Only used on double depth oven to increase pipe pressure before steaming.

### **CHART INTERVAL –**

Time interval, in seconds, that the bars show on the heat and bake time progress charts.

### **SOUNDER SELECT –**

Set as external or onboard.

### **SOUNDER TONE –**

Select a tone – Voice, Tone or Off

### **SOUNDER VOLUME –**

Adjust to suit the volume required. (onboard sounder only)

### **SHORTCUT BUTTONS –**

**1 fn**

**2 fn**

**3 fn**

**4 fn**

**5 fn**

Gives the choice of what buttons are active and in which order they appear on the options screen.

Options available = Favourites, Programs, Manual bake, Multi bake, 7-day timer . (Settings at **6fn** cannot be changed)

# OVEN SETTINGS (HIGH LEVEL)

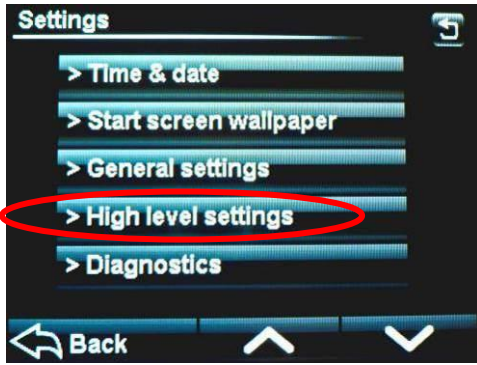

TOUCH "HIGH LEVEL SETTINGS" AND THE FOLLOWING SCREEN WILL APPEAR.

1

SETTINGS SCREEN



ENTER "HIGH LEVEL" PASSCODE AND THEN TOUCH OK.

2

THE FOLLOWING SCREEN WILL APPEAR.

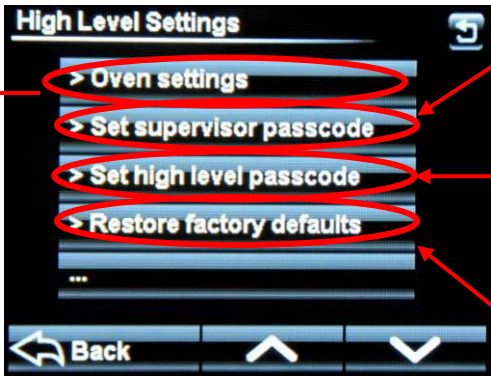

CHANGE SUPERVISOR PASSCODE HERE

CHANGE HIGH LEVEL PASSCODE HERE

RESTORES ALL SCREENS BACK TO ORIGINAL DEFAULT SETTINGS (NOT PASSCODES)

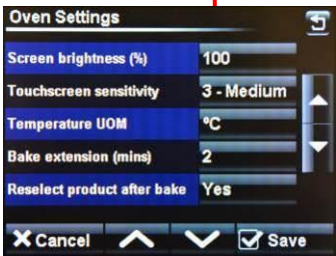

SCROLL DOWN TO MOVE THROUGH ALL CHOICES AND ADJUST EACH ONE AS REQUIRED, USING THE ARROW KEYS.

3

## **OVEN SETTINGS EXPLAINED - HIGH LEVEL**

### **OVEN TYPE –**

Set this to DX.

### **MAX. BAKE TEMPERATURE –**

Can be set up to 300C , (depending on the oven type)

### **TEMPERATURE OFFSET –**

Can be used to adjust the display to the actual temperature in the oven.

### **BAKE HYSTERISIS –**

Sets bake temperature cycling around a set point. (Above and below).

### **BAKE CYCLE SET POINT ONLY –**

No = Shows set temperature point and actual temperatures on screen.

YES = shows set temperature point only

### **MANUAL DEFAULT TEMPERATURE –**

Set for manual program default temperature

### **SLEEP FALLBACK –**

Temperature of the oven in “sleep mode” (100C is suggested).

### **SLEEP HYSTERISIS –**

Sets “sleep mode” temperature cycling around a set point. (Above and below).

### **READY ACCEPT HIGH –**

Highest temperature for the oven to display “READY”

### **READY ACCEPT LOW –**

Lowest temperature for the oven to display “READY”

### **STEAM TYPE –**

Plate or trough.

### **TOP GAIN –**

0-255 centigrade

### **BOTTOM GAIN –**

0-255 centigrade

### **MONO CONSTANT –**

Factory set **(Do not change unless instructed to do so)**

### **STEAM TROUGH TEMP –**

Degrees Centigrade

### **STEAM HYSTERISIS –**

Degrees Centigrade

### **STEAM TROUGH EXCEPT –**

Degrees Centigrade

**LIGHT OUTPUT SOFT START –**

On/Off Some lights need this for cold start up to stop them blowing.

**HEATER CONTROL –**

Contact or solid state. Defaults to contactor. (solid state not used at the moment)

**I/O DIAGNOSTIC –**

Displays outputs and inputs at the top of the screen to aid fault finding if needed.

## DEFAULT PASSCODES

**SUPERVISOR (LOW LEVEL) -- 123456**

**HIGH LEVEL -- 654321**

MASTER -- 314159 (This is fixed)

### **SUGGESTION**

To stop unauthorised changes to the oven setup, it is suggested that this page is removed from this manual and kept in a safe place for future reference.

If tampering could be a problem, it is a good idea to change the passcodes at regular intervals.

## CHANGING PASSCODES

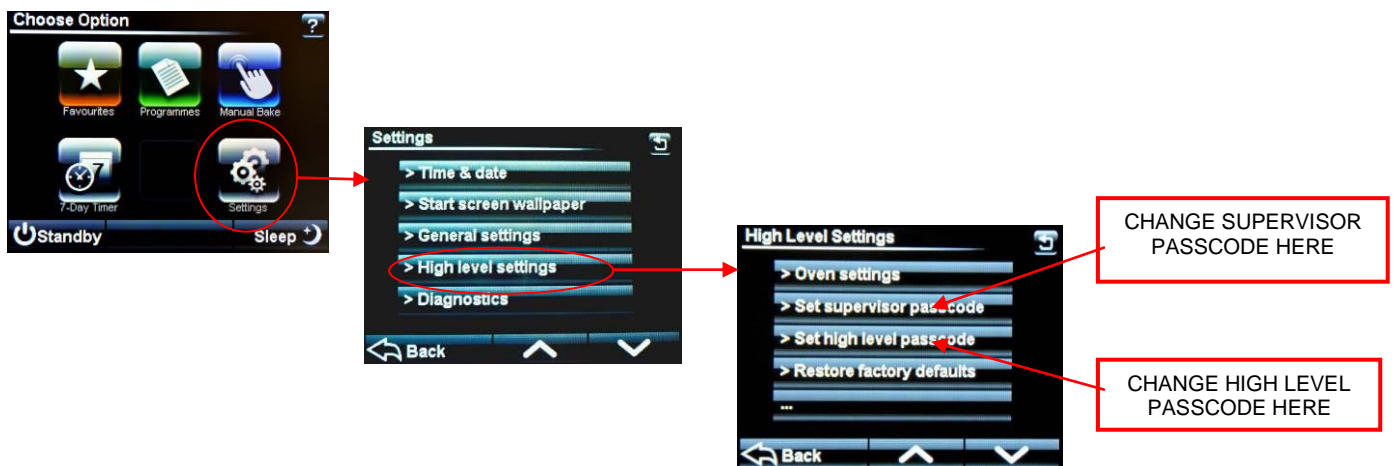

**NOTE**  
PASSCODES WILL BE REQUIRED TO GO THROUGH THESE SCREENS AND MAKE CHANGES.

# 10 - 7 USING THE USB PORT

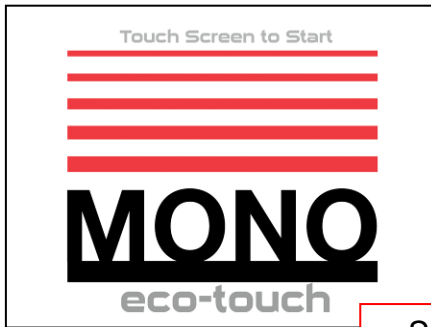

START SCREEN

Ensure the Start screen is showing

1



Insert the USB memory stick into the socket on the oven panel. (Rubber plug may have to be removed first).

2

NOTE

The USB stick will only fit in one way.  
Do not force into the socket.



Wait for the USB symbol to finish moving

3

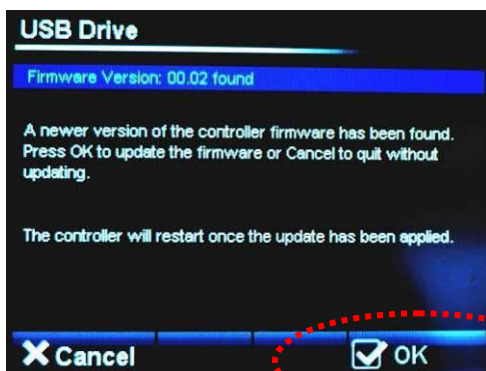

If old firmware is found, the firmware version screen will appear.

Touch "OK" to update firmware

-Wait-

Remove USB stick

OR

Touch "CANCEL" to choose other items to update or change.

(see next page)

4



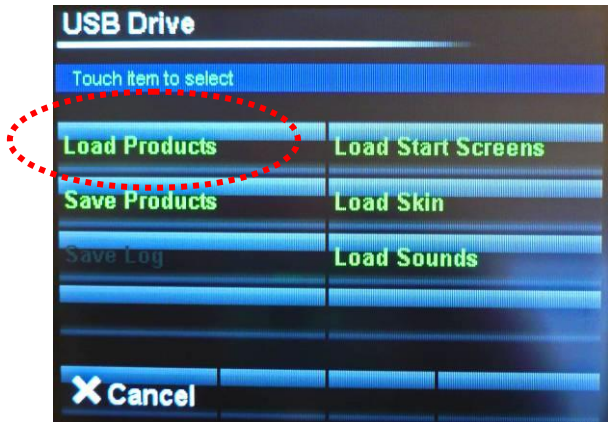

Choose action you would like to do. **5**



Select the file required. **6**

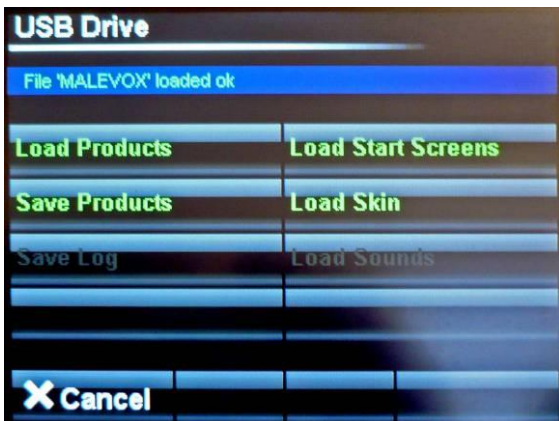

When confirmation of "file loaded ok" Shows, remove the usb stick. **7**

# NOTES ON USING USB STICKS

For a USB stick to function correctly it must have the following folder as a root folder .

## **Mono**

Then into that folder create the following:

- Firmware**
- Products**
- Skins**
- Sounds**
- Startup**

Place your recipe/product files in the “**products**” folder.

The oven will find the “**Mono**” folder automatically when the stick is plugged into the oven. Any stick can be used (does not have to be blank) but the Mono folder must be in the root.

The most used folders are explained below:

## **SKINS**

These control the way the screen looks in different modes.

**Pictorial** is when the screen displays categories using pictures.



**Numerical** is when the screen displays program numbers.



## **STARTUP SCREENS**

This is the picture/logo you see when the oven is started.



## **PRODUCT FILES (PROGRAM FILES)**

These are the files that contain the information for baking each product e.g. bread,buns,cakes etc.

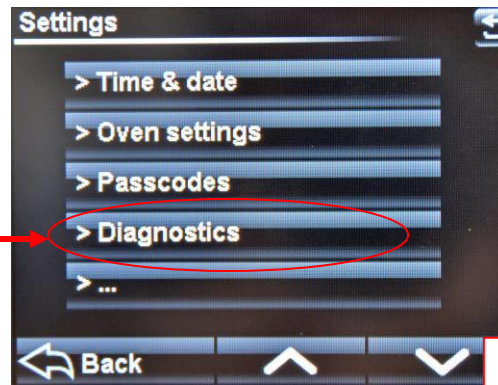

SETTINGS SCREEN

TOUCH "DIAGNOSTICS" AND THE FOLLOWING SCREEN WILL APPEAR.



DIAGNOSTICS SCREEN

INPUTS HIGHLIGHT WHEN A SIGNAL IS Received.  
e.g. DOOR OPEN

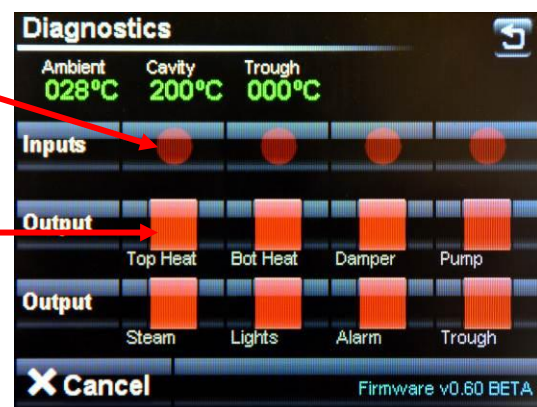

TOUCH THE REQUIRED OUTPUT AND A SIGNAL IS SENT TO THAT ITEM. THE OUTPUT BEING CHECKED IS HIGHLIGHTED WHEN ACTIVE. TO STOP THE OUTPUT, PRESS AGAIN.

## 11.0 TROUBLESHOOTING

---

### ▪ NONE OF THE DECKS SWITCHED ON.

- Is main oven power on?
- Check if bakery main power supply time clock is working (if fitted).
- Is 7-day timer clock set correctly to bring oven on at required time?

### ▪ ONE DECK HAS NOT SWITCHED ON.

- Check if individual deck timer is set to bring it on at required time.

### ▪ UNEVEN OR PATCHY BAKE

- Door is being opened too often or too long whilst loading.  
(front pale, back burnt).
- Faulty element.
- All top or bottom deck elements not functioning.
- Uneven loading.
- No supply voltage across a phase.

### ▪ TEMPERATURE GOING WELL OVER SET TEMPERATURE

When empty the temperature of a deck oven can exceed the set baking temperature. This overheat is marginal when the deck is full of product. If the elements are continuing to work after the set temperature has been reached call Mono service.  
(Please allow up to 15deg.C difference before diagnosing a fault condition),

### ▪ POOR RECOVERY OF SET TEMPERATURE WHEN LOADED

- The doors may have been left open too long during loading, allowing heat to escape.
- The damper may have been left open during loading or baking allowing heat to escape.
- Top and/or bottom heat may not be working or set at a low value.
- No supply voltage across a phase.

### ▪ STEAM SYSTEM NOT OPERATING CORRECTLY

Check that the water supply is connected and the tap to each deck is in the on position.  
If there is still a problem, Contact Mono.

## 12.0 SERVICE

---

If a fault arises, please do not hesitate to contact the Customer Service Department, quoting the **machine serial number** on the silver information plate of the machine and on the front cover of this manual

**MONO**

Queensway  
Swansea West Industrial Estate  
Swansea. SA5 4EB UK

**email:spares@monoequip.com**  
**Spares Tel. +44(0)1792 564039**

**Web site:www.monoequip.com**  
**Main Tel. +44(0)1792 561234**

**Fax. 01792 561016**

# LIGHT REPLACEMENT

**DISCONNECT FROM POWER SUPPLY BEFORE REPLACING LIGHT BULBS**

24v 20w LAMP PART NUMBER ... B855-94-008



HEX HEAD SOCKET SCREWS

1

UNSCREW PLATE NEXT TO LIGHT TO BE REPLACED



2

SLIDE FITTING OUT



3

REMOVE LIGHT FROM HOLDING SLOT AND UNCLIP FROM CABLE



4

REPLACE LIGHT AND REFIT ALL PARTS

RECONNECT POWER SUPPLY AND TEST



## 13.0 SPARES INFORMATION

## OVEN SPARES

FROSTED GLASS (LIGHTS)	M257-02-00027
PLAIN GLASS (LIGHTS)	M257-02-00028
DOOR BUMPER STOP	M257-03-00027
BAKING TILE 3 ACROSS	M257-02-00046
2 ACROSS	M257-02-00047
1 ACROSS	M257-02-00048
HINGE PIN RHS	M257-03-00005
HINGE PIN LHS	M257-03-00009
BLACK DOOR HANDLE	A900-27-192
DOOR SPRING	M257-03-00017
WIRE ROPE	M257-03-00024
SPRING RETAINING PIN	M257-03-00025
PULLEY	M257-03-00015
PULLEY SPINDLE	M257-03-00013
DAMPER DRIVE COUPLING	M257-07-00007
ELEMENT GASKET	M245-02-01300
24 v 20w DICHROIC LAMP	B855-94-008



## ELEMENT SPARES

### 3 ACROSS

TOP HEAT ELEMENT 1.0kW	B854-04-093
TOP HEAT ELEMENT 0.6kW	B854-04-091
BOTTOM HEAT ELEMENT 0.75kW	B854-04-092

### 2 ACROSS

TOP HEAT ELEMENT 0.65kW	B854-04-102
TOP HEAT ELEMENT 0.4kW	B854-04-100
BOTTOM HEAT ELEMENT 0.5kW	B854-04-101

### 1 ACROSS

TOP HEAT ELEMENT 0.325kW	B854-04-111
TOP HEAT ELEMENT 0.2kW	B854-04-109
BOTTOM HEAT ELEMENT 0.25kW	B854-04-110



## 14.0 ELECTRICS

**PARTS LIST FOR DRAWINGS FOLLOWING – 3 TRAY WIDE**

F1	HEATERS MCB	B872-22-007	Single phase only
F2	HEATERS MCB	B872-22-007	
F3	HEATERS MCB	B872-22-007	
F4	CONTROL POWER SUPPLY MCB	B872-22-062	
F5	OVERHEAT THERMOSTAT	B888-30-014	
T1	CONTROL CIRCUIT POWER SUPPLY	B801-93-005	
K1	TOP HEAT CONTACTOR	B801-08-021	
K2	BOTTOM HEAT CONTACTOR	B801-08-021	
Y1	WATER SOLENOID (8mm pipe)	A900-34-365	
H1	INTERIOR LIGHT	B855-94-008	
B1	OVEN THERMOCOUPLE	B873-95-007	
U1	MAIN ECO PRINTED CIRCUIT BOARD	M158-25-80000	
D1	DAMPER SOLENOID	B749-83-004	
R1	TOP HEAT ELEMENT 1.0kW	B854-04-093	
R2	TOP HEAT ELEMENT 0.6kW	B854-04-091	
R3	TOP HEAT ELEMENT 0.6kW	B854-04-091	
R4	TOP HEAT ELEMENT 0.6kW	B854-04-091	
R5	TOP HEAT ELEMENT 0.6kW	B854-04-091	
R6	TOP HEAT ELEMENT 0.6kW	B854-04-091	
R7	TOP HEAT ELEMENT 0.6kW	B854-04-091	
R8	BOTTOM HEAT ELEMENT 0.75kW	B854-04-092	
R9	BOTTOM HEAT ELEMENT 0.6kW	B854-04-091	
R10	BOTTOM HEAT ELEMENT 0.6kW	B854-04-091	
R11	BOTTOM HEAT ELEMENT 0.6kW	B854-04-091	
R12	BOTTOM HEAT ELEMENT 0.6kW	B854-04-091	
R13	BOTTOM HEAT ELEMENT 0.6kW	B854-04-091	
R14	BOTTOM HEAT ELEMENT 0.6kW	B854-04-091	

## **PARTS LIST FOR DRAWINGS FOLLOWING – 2 TRAY WIDE**

F1	HEATERS MCB	B872-22-006	Single phase only
F2	HEATERS MCB	B872-22-006	
F3	HEATERS MCB	B872-22-006	
F4	CONTROL POWER SUPPLY MCB	B872-22-062	
F5	OVERHEAT THERMOSTAT	B888-30-014	
T1	CONTROL CIRCUIT POWER SUPPLY	B801-93-005	
K1	TOP HEAT CONTACTOR	B801-08-021	
K2	BOTTOM HEAT CONTACTOR	B801-08-021	
Y1	WATER SOLENOID (8mm pipe)	A900-34-365	
H1	INTERIOR LIGHT	B855-94-008	
B1	OVEN THERMOCOUPLE	B873-95-007	
U1	MAIN ECO PRINTED CIRCUIT BOARD	M158-25-80000	
D1	DAMPER SOLENOID	B749-83-004	
R1	TOP HEAT ELEMENT 0.65kW	B854-04-102	
R2	TOP HEAT ELEMENT 0.4kW	B854-04-100	
R3	TOP HEAT ELEMENT 0.4kW	B854-04-100	
R4	TOP HEAT ELEMENT 0.4kW	B854-04-100	
R5	TOP HEAT ELEMENT 0.4kW	B854-04-100	
R6	TOP HEAT ELEMENT 0.4kW	B854-04-100	
R7	TOP HEAT ELEMENT 0.4kW	B854-04-100	
R8	BOTTOM HEAT ELEMENT 0.5kW	B854-04-101	
R9	BOTTOM HEAT ELEMENT 0.4kW	B854-04-100	
R10	BOTTOM HEAT ELEMENT 0.4kW	B854-04-100	
R11	BOTTOM HEAT ELEMENT 0.4kW	B854-04-100	
R12	BOTTOM HEAT ELEMENT 0.4kW	B854-04-100	
R13	BOTTOM HEAT ELEMENT 0.4kW	B854-04-100	
R14	BOTTOM HEAT ELEMENT 0.4kW	B854-04-100	

## PARTS LIST FOR DRAWINGS FOLLOWING – 1 TRAY WIDE

F1	HEATERS MCB	B872-22-005	Single phase only
F2	HEATERS MCB	B872-22-005	
F3	HEATERS MCB	B872-22-005	
F4	CONTROL POWER SUPPLY MCB	B872-22-062	
F5	OVERHEAT THERMOSTAT	B888-30-014	
T1	CONTROL CIRCUIT POWER SUPPLY	B801-93-005	
K1	TOP HEAT CONTACTOR	B801-08-021	
K2	BOTTOM HEAT CONTACTOR	B801-08-021	
Y1	WATER SOLENOID (8mm pipe)	A900-34-365	
H1	INTERIOR LIGHT	B855-94-008	
B1	OVEN THERMOCOUPLE	B873-95-007	
U1	MAIN ECO PRINTED CIRCUIT BOARD	M158-25-80000	
D1	DAMPER SOLENOID	B749-83-004	
R1	TOP HEAT ELEMENT 0.35kW	B854-04-111	
R2	TOP HEAT ELEMENT 0.2kW	B854-04-109	
R3	TOP HEAT ELEMENT 0.2kW	B854-04-109	
R4	TOP HEAT ELEMENT 0.2kW	B854-04-109	
R5	TOP HEAT ELEMENT 0.2kW	B854-04-109	
R6	TOP HEAT ELEMENT 0.2kW	B854-04-109	
R7	TOP HEAT ELEMENT 0.2kW	B854-04-109	
R8	BOTTOM HEAT ELEMENT 0.25kW	B854-04-110	
R9	BOTTOM HEAT ELEMENT 0.2kW	B854-04-109	
R10	BOTTOM HEAT ELEMENT 0.2kW	B854-04-109	
R11	BOTTOM HEAT ELEMENT 0.2kW	B854-04-109	
R12	BOTTOM HEAT ELEMENT 0.2kW	B854-04-109	
R13	BOTTOM HEAT ELEMENT 0.2kW	B854-04-109	
R14	BOTTOM HEAT ELEMENT 0.2kW	B854-04-109	

**TOP CANOPY MK 2 DECK OVEN MCB WIRING**

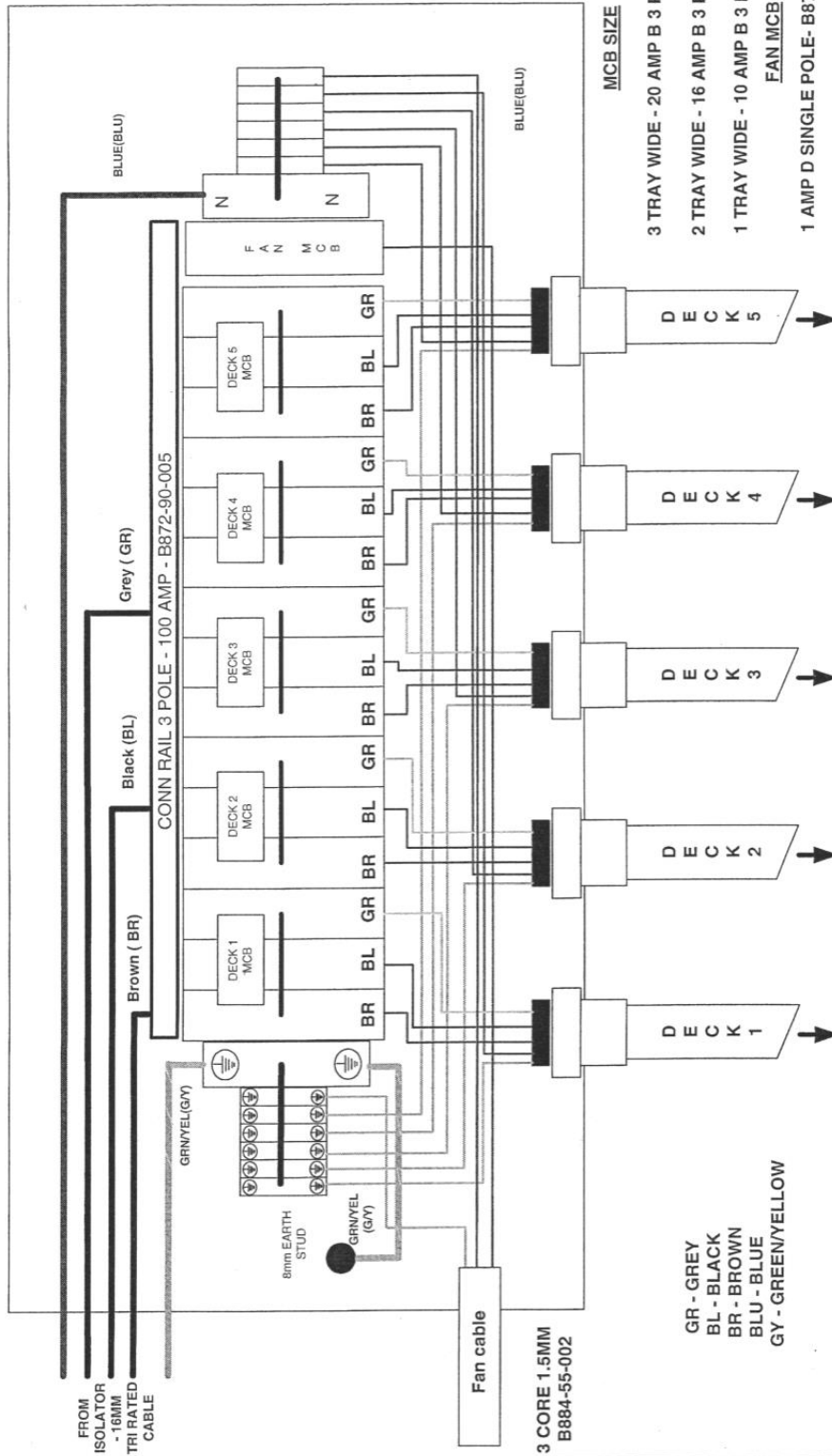

**MAINS CABLE TO EACH DECK (TB1) 2.5MM 5 CORE TYPE B B843-57-003**

MONO EQUIPMENT SWANSEA WEST IND PARK SWANSEA SA1 1 4LS TEL: (01792) 818284 FAX: (01792) 818181 Email: <a href="mailto:engineering@monocable.com">engineering@monocable.com</a>	TITLE: UK/EUROPE TOP SECTION MCB WIRING DISTRIBUTION UNIT	ELECTRICALLY APPROVED BY: ADT	REF: -
	DRAWN: ADT DATE: 19-2-07	DRAWING NO: M257E25-52300	
ELECTRICAL SPECIFICATIONS: 400V 50/60 HZ 3 PHASE + N+E			

# DX UK Modular MK2 Deck Oven Interlink Detail

DECKS ARE LINKED AS REQUIRED - 2, 3, 4 AND 5 HIGH

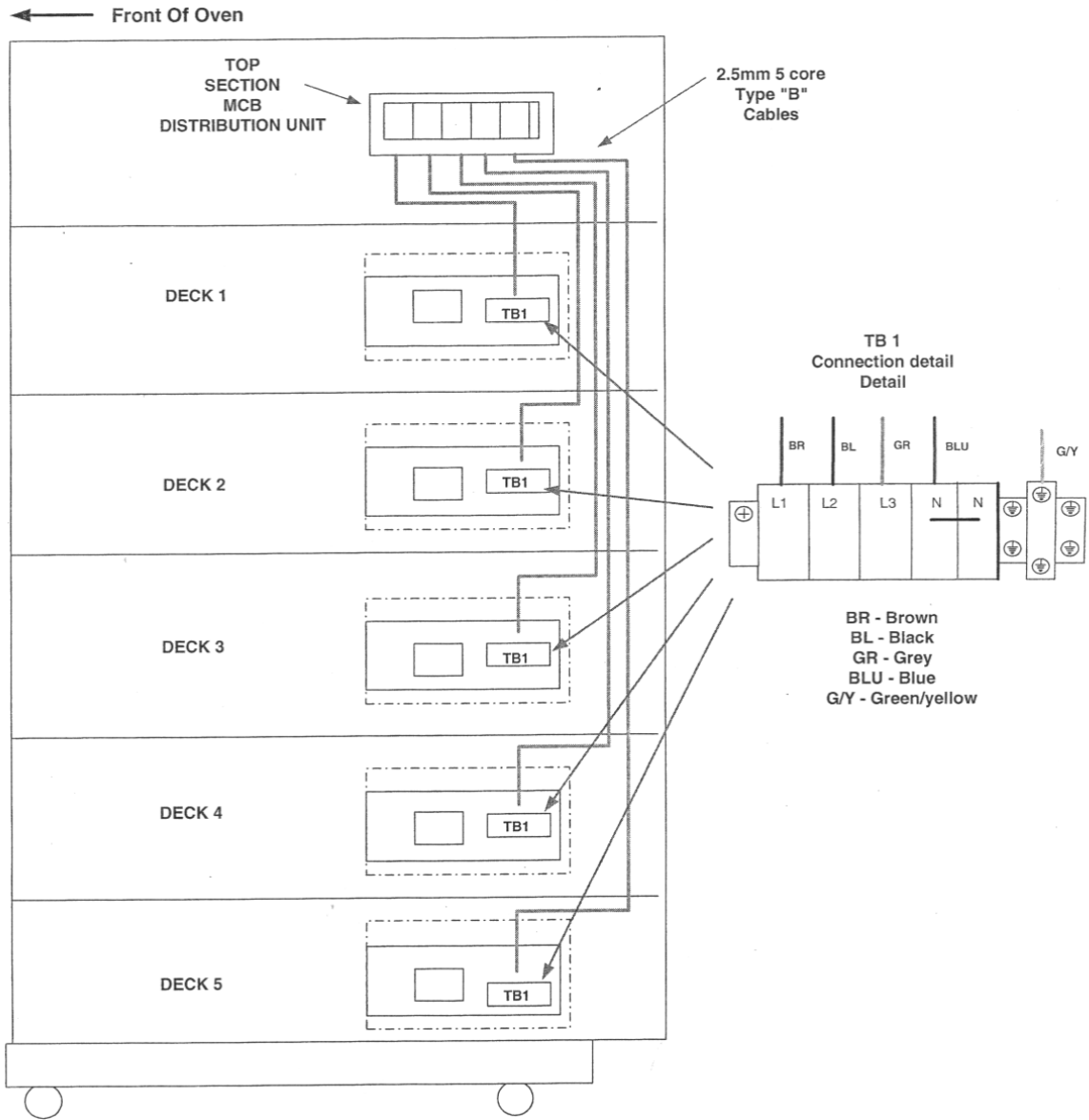

<p style="font-size: 8px; margin: 0;">MONO EQUIPMENT QUEENSWAY SWANSEA WEST RD PARK SWANSEA SA6 4JH TEL: (01792) 561224 FAX: (01792) 561216</p> <p style="font-size: 8px; margin: 0;">Email: <a href="mailto:engineering@monoquip.com">engineering@monoquip.com</a></p>	<p style="font-size: 8px; margin: 0;">TITLE: <b>UK/EUROPE MODULAR MK 2 DECK OVEN INTERLINK DETAIL</b></p>	
<p style="font-size: 8px; margin: 0;">ELECTRICAL SPECIFICATIONS:</p> <p style="margin: 0;">400V 50/60 HZ 3 PHASE + N+E</p>	<p style="font-size: 8px; margin: 0;">DRAWN: ADT</p> <p style="font-size: 8px; margin: 0;">DATE: 19-2-07</p>	<p style="font-size: 8px; margin: 0;">ELECTRICALLY APPROVED BY:</p> <p style="text-align: center; margin: 0;">ADT</p> <p style="font-size: 8px; margin: 0;">DRAWING NO.      REV:</p> <p style="text-align: center; margin: 0;">M257E25-52500      -</p>

IF IN ANY DOUBT - ASK

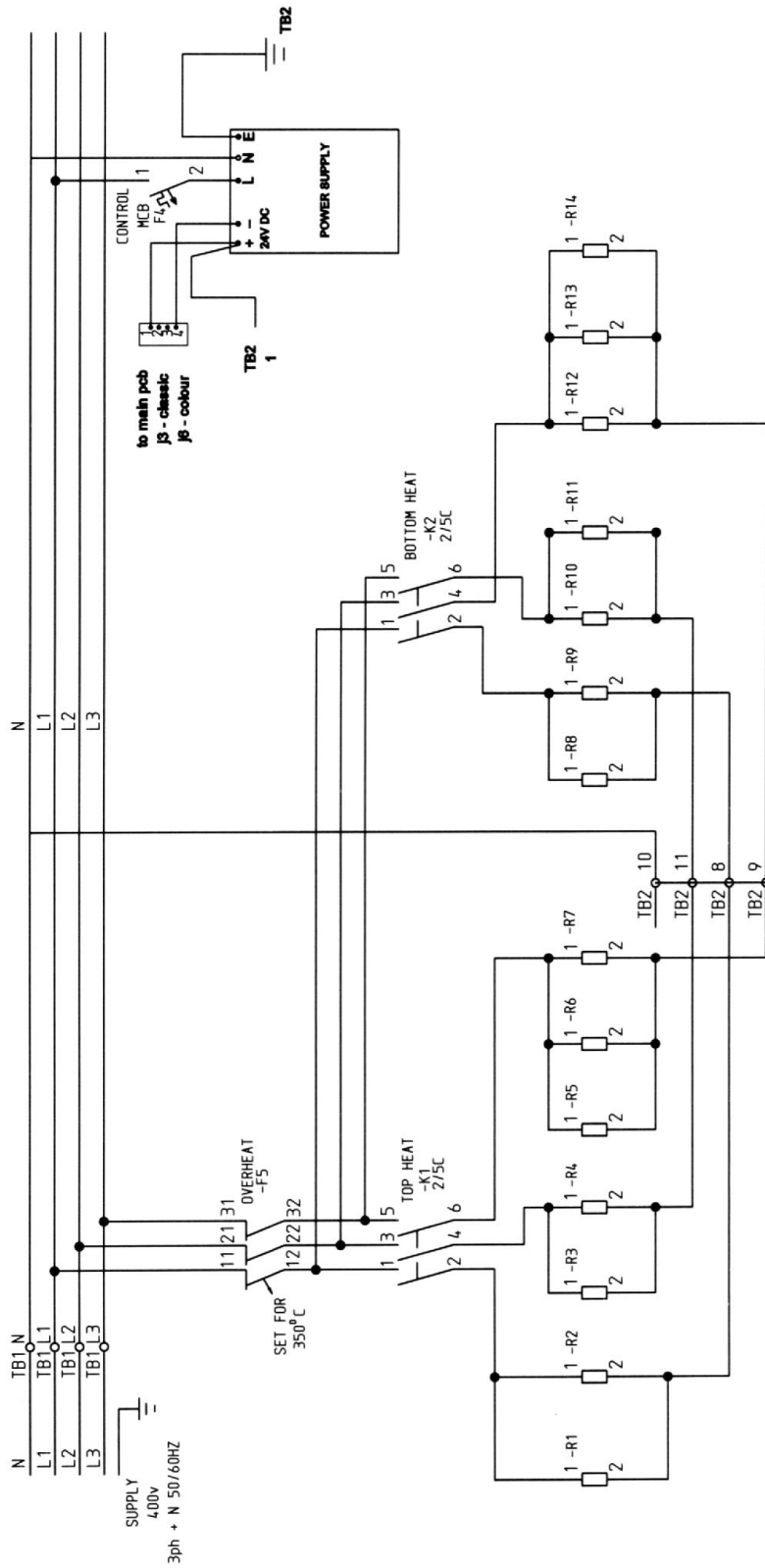

REV	SIG	DATE	REVISION	ECN NO.
<p><b>MONO EQUIPMENT</b>                  QUEENSWAY                  SWANSEA WEST IND PARK                  SWANSEA,                  SA5 4EB.                  TEL: (01792) 561234                  FAX: (01792) 561016</p>				
<p><b>TITLE:</b>                  MODULAR DECK OVEN                  POWER CIRCUIT                  TOP-BOTTOM HEAT</p>			<p><b>UK</b></p>	
<p><b>ELECTRICAL SPECIFICATIONS:-</b>                  400V 3PH &amp; N + E                  50/60 HZ</p>			<p><b>DRAWN:</b>                  RAC</p>	
<p><b>DATE:</b>                  7/3/07</p>			<p><b>DATE:</b>                  7/3/07</p>	
<p><b>REVISION</b></p>			<p><b>ELECTRICALLY APPROVED BY:-</b>                  AT</p>	
<p><b>DRAWING NO.</b>                  M257E25-30000</p>			<p><b>REV:</b>                  —</p>	

COPYRIGHT © 1998 - THIS DESIGN/DRAWING IS THE PROPERTY OF MONO EQUIPMENT LTD. AND MUST NOT BE REPRODUCED, COPIED, NOR ITS CONTENTS DIVULGED WITHOUT PRIOR WRITTEN PERMISSION.



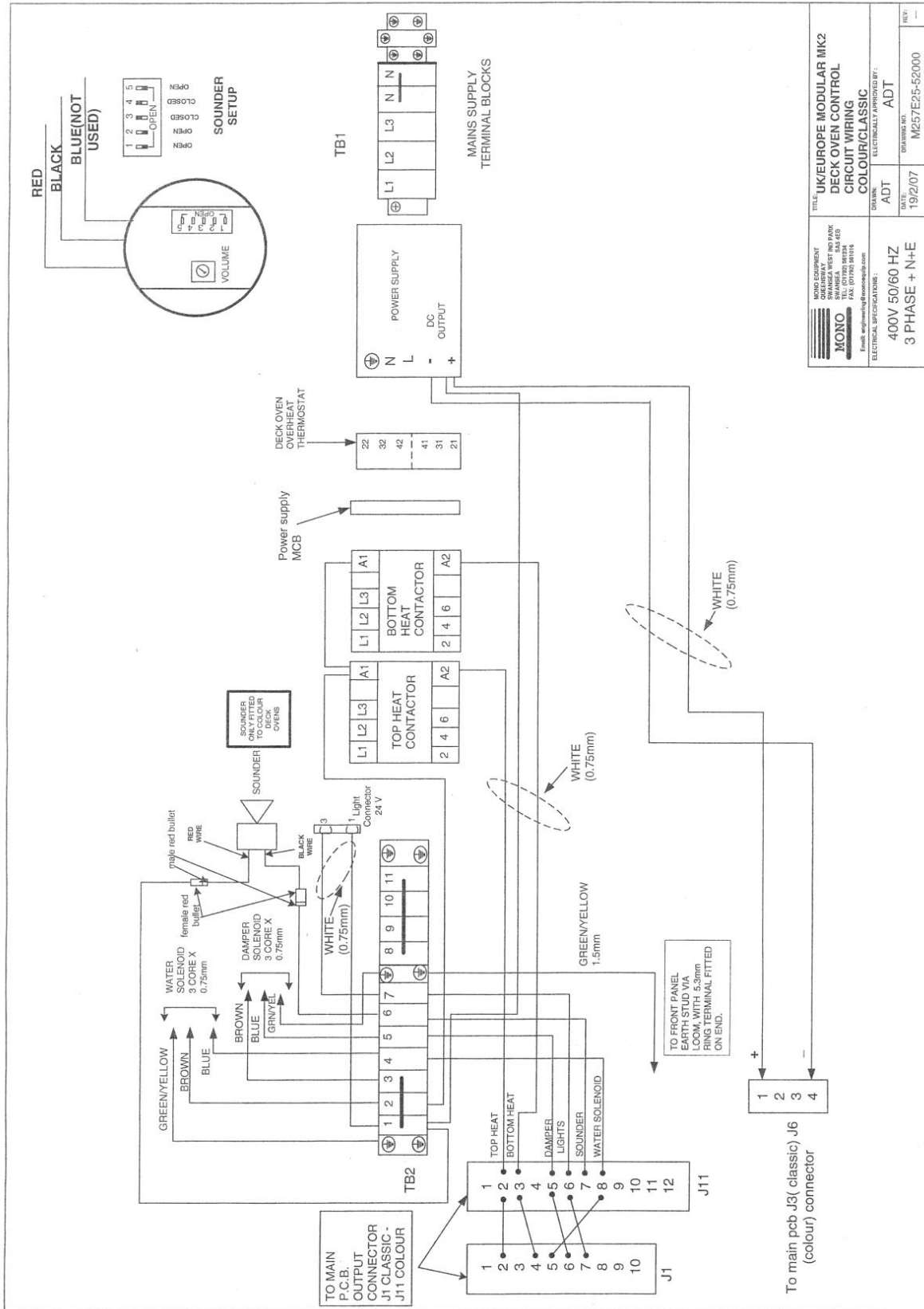

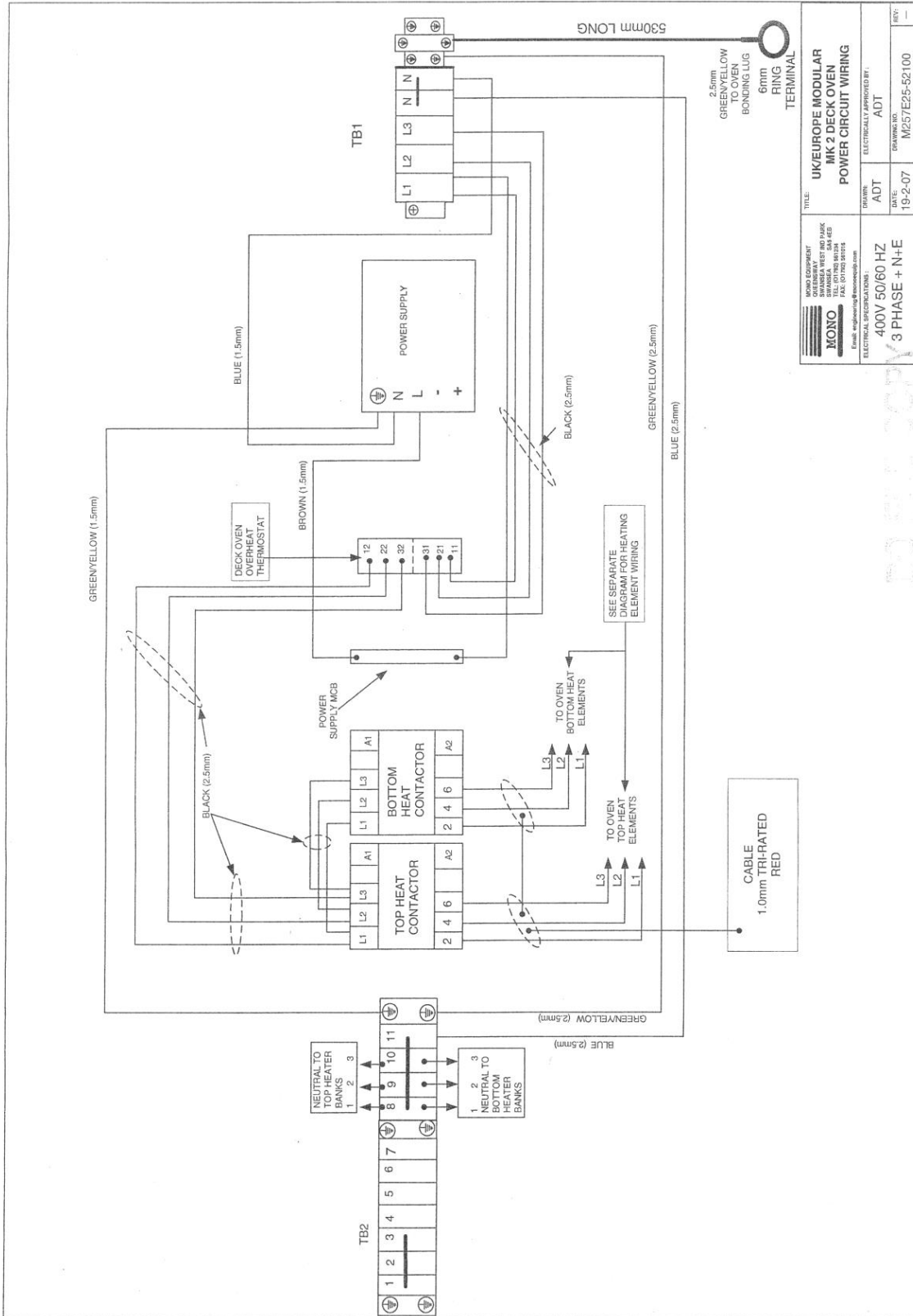

 MONO GROUP COMPANY 2000 WEST 800 PARK AVENUE SUITE 100 FORT WORTH, TEXAS 76116 TEL: (817) 835-1374 FAX: (817) 835-1375 Email: <a href="mailto:engineering@monocable.com">engineering@monocable.com</a>	TITLE <b>UK/EUROPE MODULAR          MK-2 DECK OVEN          POWER CIRCUIT WIRING</b>
	DRAWN ADT
ELECTRICAL SPECIFICATIONS <b>400V 50/60 HZ          3 PHASE + N+E</b>	ELECTRICALLY APPROVED BY: ADT
DATE 19-2-07	DRAWING NO. M257E25-52100
REV: -	

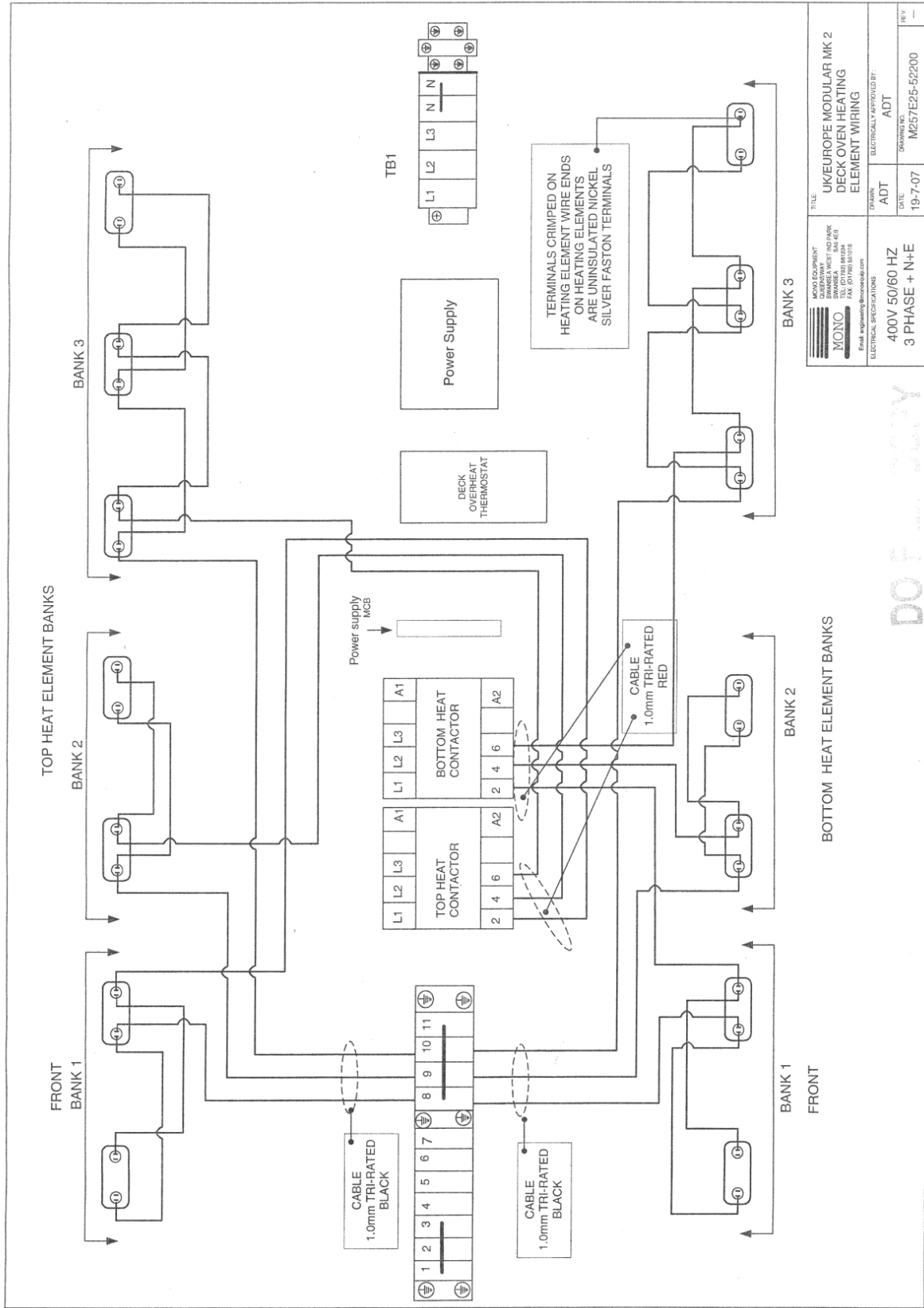

DOF

**MODULAR DECK MK 2 MAIN ISOLATOR WIRING**

**MAIN ISOLATOR**  
VCCF4  
B801-07-002

**NEUTRAL BLOCK**  
VZ12  
B801-14-017

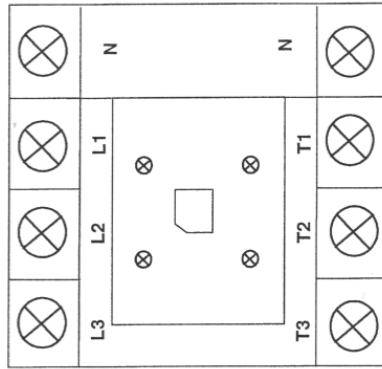

16MM TRI RATED CABLE

TOP SECTION MCB DISTRIBUTION UNIT

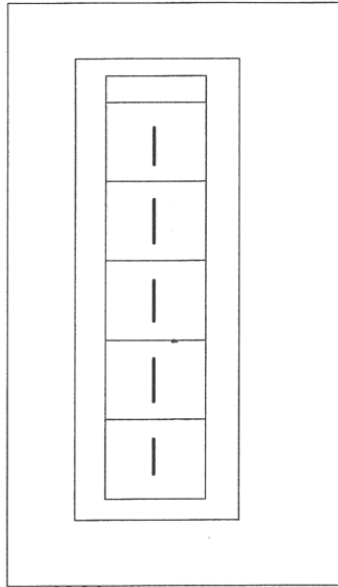

GR - GREY  
BL - BLACK  
BR - BROWN  
BLU - BLUE  
GY - GREEN/YELLOW

<p>MONO EQUIPMENT 1000 WEST ROAD SWANSEA, WEST MID PARK SWANSEA, SA1 8EP WALES SA1 8EP TEL: 01792 881914 FAX: 01792 881914 Email: <a href="mailto:engineering@monoequip.com">engineering@monoequip.com</a></p>	<p><b>UK/EUROPE MODULAR MK 2 DECK OVEN ISOLATOR WIRING</b></p>	
	<p>DATE: 19-2-07</p>	<p>DRAWING NO: M257E25-52400</p>
<p>ELECTRICAL SPECIFICATIONS:</p> <p>400V 50/60 HZ 3 PHASE + N+E</p>	<p>DRAWN: ADT</p>	<p>ELECTRICALLY APPROVED BY: ADT</p>
		<p>REV: —</p>

# ELECTRICAL PANEL MAIN COMPONENTS

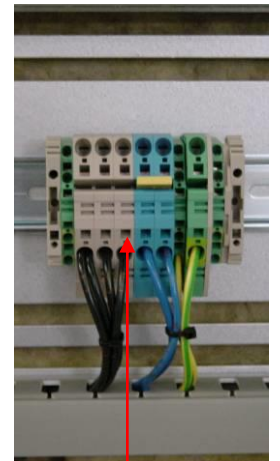
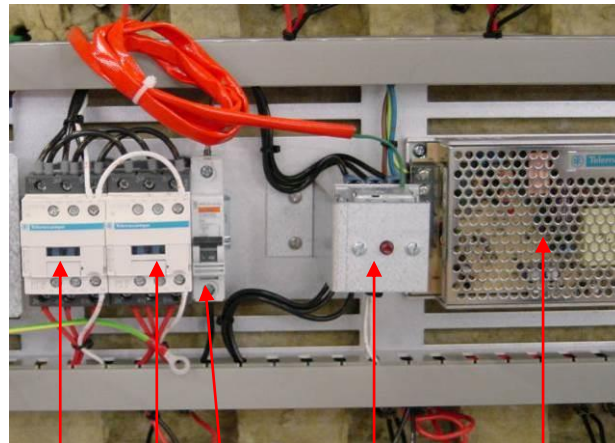
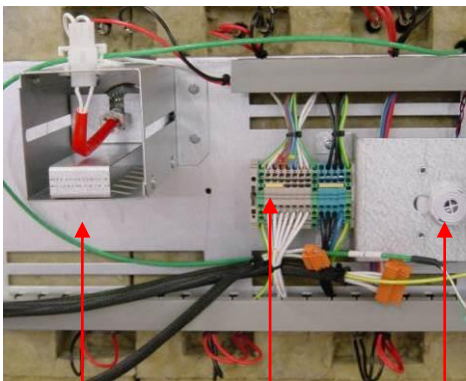
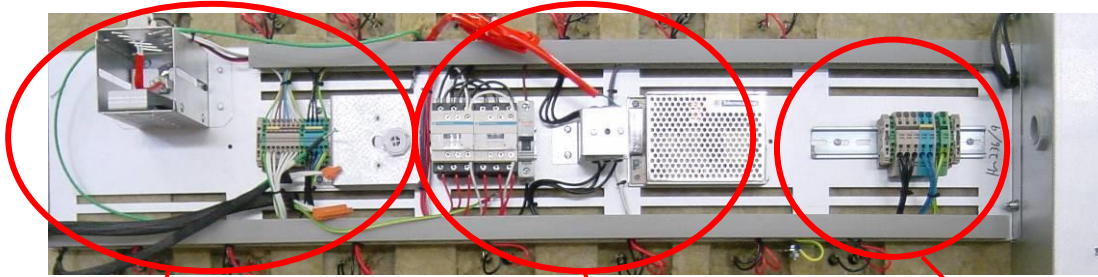

H1

TB2

S1  
OPTIONAL

K1

K2

F4

F5

POWER SUPPLY

TB1

## OVEN CANOPY LAYOUT PARTS LIST

C1	CANOPY FAN CAPACITOR	B869-23-005
Q1	CANOPY FAN ON/OFF SWITCH	B895-07-005
M1	CANOPY FAN MOTOR	B869-75-026
	CAPACITOR – 4-6uf – 400VDB – METAL	B869-23-005
	FAN TYPE R2E225-AG01-21 (230V, 0.88AMP, 200W)	B869-75-026

# 15.0 WARNING AND INFORMATION LABELS

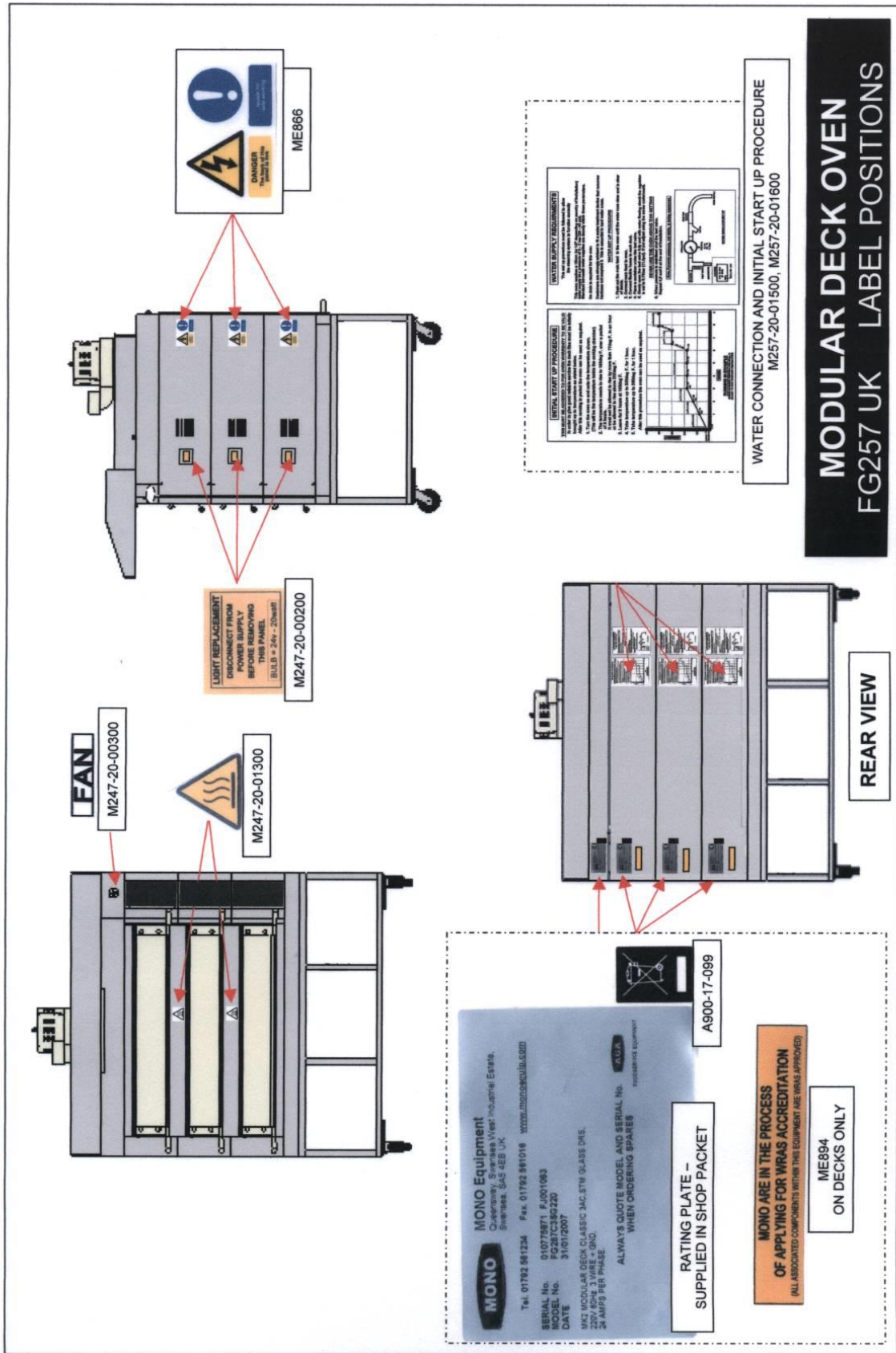



**MONO Equipment**

Queensway, Swansea West Industrial Park, Swansea, SA5 4EB UK

Tel. 01792 561234

Spares +44(0)1792 564039

Fax. 01792 561016

Email: [mono@monoequip.com](mailto:mono@monoequip.com)

**[www.monoequip.com](http://www.monoequip.com)**

As it is our policy to improve our machines continuously, we reserve the right to change specifications without prior notice.

▪ **DISPOSAL**

Care should be taken when the machine comes to the end of its working life. All parts should be disposed of in the appropriate place, either recycling or other means as the law permits at the time.